



INSTALLATION AND OPERATING MANUAL

OIL BURNING STOVE EVEREST

Vérifié and tested following
CAN/CSA B140.3 et UL 896 standards by:

Intertek Testing Services
Warnock Hersey



Fabricated by:



STOVES & FIREPLACES

1700 Léon-Harmel
Québec, (Québec)
G1N 4R9

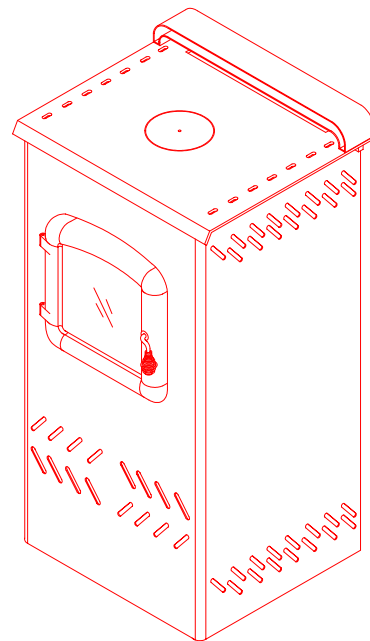

READ THESE INSTRUCTIONS AND SAVE FOR REFERENCE

TABLE OF CONTENT

| | |
|--|----------|
| TECHNICAL DATA | 1 |
| INSTALLATION INSTRUCTIONS..... | 2 |
| LOCATING THE STOVE | 2 |
| CHIMNEY INFORMATIONS | 3 |
| CONNECTING THE STOVE TO THE CHIMNEY..... | 4 |
| LEVELING THE UNIT | 5 |
| FIXATION OF STOVE TO FLOOR..... | 6 |
| CONNECTING STOVE TO OIL TANK | 6 |
| AJUSTEMENT THE DRAUGHT | 7 |
| OPERATION INSTRUCTIONS..... | 8 |
| COMBUSTIBLE..... | 8 |
| LIGHTING PROCEDURES..... | 8 |
| CHANGING INTENSITY | 9 |
| TURNING THE STOVE OFF | 9 |
| CLEANING PROCEDURES | 9 |
| TROUBLESHOOTING GUIDE..... | 10 |

TECHNICAL DATA EVEREST OIL BURNING STOVE

| COMBUSTIBLE : | OIL N° 1 | | OIL N° 2 | |
|-----------------------------------|-----------------|----------|-----------------|----------|
| HEAT INPUT : | Kw | BTU/h | Kw | BTU/h |
| Minimum: | 5,9 | 20 450 | 4,8 | 16 600 |
| Maximum: | 10,9 | 37 250 | 9,6 | 33 150 |
| FLOWRATE : | cc/min | litres/h | cc/min | litres/h |
| Minimum: | 9,9 | 0,60 | 7,5 | 0,45 |
| maximun: | 17,3 | 1,04 | 16,1 | 0,97 |
| MINIMUM DRAUGHT REQUIRED : | 0,06 INWC | | 0,06 INWC | |
| EFFICIENCY : | % | | % | |
| with fan : | 78,5 | | 79 | |
| without fan : | 77 | | 77 | |

CLEARANCES TO COMBUSTIBLES

| | Mm | in |
|--------|-----|----|
| Back | 255 | 10 |
| Side | 255 | 10 |
| Corner | 255 | 10 |
| Top | 915 | 36 |

A MINIMUM CLEARANCE OF 9" (230 mm) FROM SINGLE WALL FLUE PIPE TO COMBUSTIBLES MUST BE ALLOWED.

DIMENSIONS

| | mm | in |
|----------------------|----------|---------------|
| Height : | 990 | 39 |
| Width : | 520 | 20 |
| Depth : | 680 | 26 ¾ |
| Ø outlet flue pipe : | 130 | 5 |
| Ø burner : | 255 | 10 |
| Glass (3) : | 92 x 250 | 3 5/8 x 9 7/8 |
| Weight : | 93 kg | 204 lbs |

INSTALLATION INSTRUCTIONS

LOCATING THE STOVE

- Install the stove as close to the chimney as possible.
- Many configurations are possible, the most frequent are illustrated in figures 1, 2 and 3.
- Respect clearances indicated on page 1. They have been tested according to approvals.
- Always respect clearances of stove pipes manufacturers. Larger clearances always prevail.

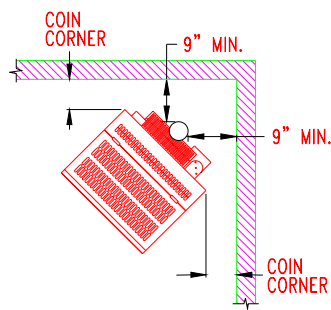

Figure 1 : CORNER INSTALLATION

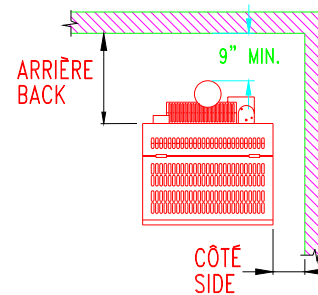

Figure 2 : PARALLEL INSTALLATION

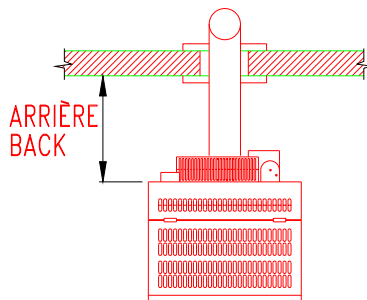

Figure 3 : WALL INSTALLATION

Table 1 : CLEARANCES TO COMBUSTIBLES

| | mm | in |
|-----------|-----|----|
| Back | 255 | 10 |
| Side | 255 | 10 |
| Corner | 255 | 10 |
| Top | 915 | 36 |
| Flue Pipe | 230 | 9 |

- **IMPORTANT:** It is essential to ensure that the room where the stove is located is sufficiently ventilated to provide an adequate air supply.
- If your home is well insulated, it is possible that you will have to install an outside fresh air intake.

THE BURNING OF ONE LITRE OF FUEL (OIL) REQUIRES APPROXIMATELY 30 M³ OF AIR AND WILL PRODUCE ABOUT 0.8 KG OF WATER OF WATER VAPOR AND 9 M³ OF CARBONE DIOXIDE AND ATMOSPHERIC NITROGEN. A SOURCE OF AIR FROM THE OUTSIDE IS NEEDED TO REPLACE COMBUSTION AIR.

CHIMNEY INFORMATIONS

- Before the hook up of the stove, check if the chimney is in good condition and that the quality of the flue pipe will allow a sufficient draught. For a good combustion, refer to the technical data of the stove to know the minimum draught required.
- Factory built "A" type chimney or "L" type chimney are approved for this unit. The chimney has to be well insulated. A chimney too cold can affect the gas temperature and lower draught effects. Low gase temperature will tend to condense and freeze or leak in your chimney.
- 5" factory built chimney is required. Using a larger flue tends to expand combustion gas and cools them off which has for result of lowering the draught effects. Gas expansion reduces the speed of the draught and have the same effects.
- When the unit is installed on a maconary chimney witch is often oversize, it's required to use a stainless steel liner of 5" diameter inside the existing chimney.
- The chimney has to reach a minimum of 15' high (including stove pipes). The chimney has to extend not less than 3' above the point it exits the roof and 2' higher than any roof, building other obstacle within a horizontal distance of 10'.

- **CHIMNEY MINMUM HEIGHT :**
Height of chimney should inferior than 15' (4.6 m).

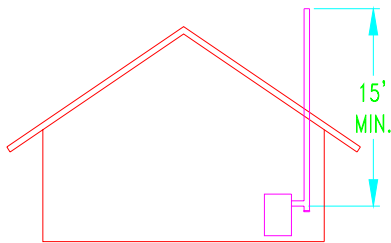

Figure 4: CHIMNEY MINMUM HEIGHT

- **CLEARANCES WITH ROOF SUMMIT AND BUILDING NEARBY :**
The chimney flue shall extend at least 2' (0,6 m) above the highest roof surface or structure within 10' (3,0 m) horizontally of the chimney.

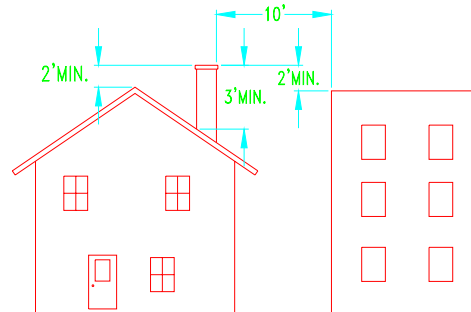

Figure 5: CHIMNEY CLEARANCES

- **CLEARANCE FROM ROOFING INTERSECTION :**
The chimney flue shall extend at least 3' (0,9 m) above the highest point at wich it comes in contact with the roof.

YOUR APPLIANCE SHALL BE CONNECTED TO CHIMNEY HAVING SUFFICIENT DRAUGHT AT ALL TIMES TO ASSURE SAFE AND PROPER OPERATION OF THE BURNER.

CONNECTING THE STOVE TO THE CHIMNEY

- The gases are vented from the back of the unit. The female part of the black pipe connector has to be installed toward the flue connector of the stove. Secure all connections with the (3) self tapping screws, with 120° distance between each of them.
- The connection between stove pipes and chimney has to be perfectly sealed.
- A maximum horizontal length of 8' is allowed. Make sure to have a 1/4" slope per foot minimum.
- Do not use more than two 90° Elbows while connecting the stove to the chimney.
- It is strictly forbidden to pass through combustible materials walls, floors and ceilings with stove pipe connectors.

- **DIRECT HORIZONTAL CONNECTION :**
You may choose to connect your stove to the chimney with an horizontal flue pipe.

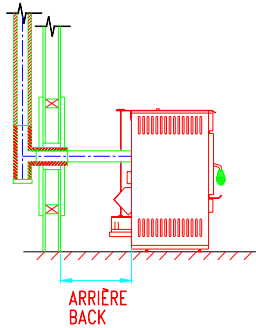

Figure 6: HORIZONTAL CONNECTION .

- **CEILING CONNECTION :**
In the case where your chimney starts from the ceiling, use one 90° elbow and the necessary straight sections.

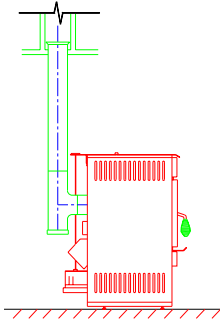

Figure 7: CEILING CONNECTION .

- DO NOT CONNECT MORE THAN ONE STOVE TO YOUR CHIMNEY.
- FIX FLUE PIPES TOGETHER WITH METAL SCREWS.
- MAKE SURE YOU RESPECT A 1/4" SLOPE PER FOOT OF HORIZONTAL PIPE LENGTH.
- RESPECT CAREFULLY CLEARANCES TO COMBUSTIBLES PRESCRIBED BY FLUE PIPES MANUFACTURERS.
- FLUE PIPES CLEARANCES TO COMBUSTIBLES DEPEND ON FLUE PIPES TYPE AND MANUFACTURERS

- **VERTICAL CONNECTION :**
It is recommended to not use more than two (2) 90° elbows and the necessary straight sections to connect your stove to the chimney.

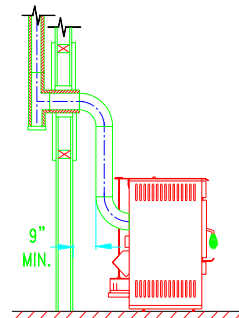

Figure 8: VERTICAL CONNECTION .

LEVELING THE UNIT

- Now that the stove is in place and properly hooked up to the chimney, you have to adjust the level on the burner.
- Put the level in the middle of the burner parallel to the door. (Figure 9A). Screw or unscrew the adjustable legs to level the burner with a 7/16" key (10 mm).
- Put the level in the middle of the burner parallel to the sides. (Figure 9B). Screw or unscrew the adjustable legs to level the burner with a 7/16" key.

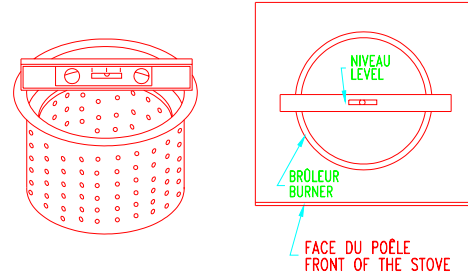

Figure 9A: LEVELLING THE BURNER

IMPORTANT :
IT IS VERY IMPORTANT TO LEVEL THE BURNER TO ALLOW A PROPER OIL VAPOR DISTRIBUTION THROUGH THE RINGS, AND A BETTER OIL INLET.

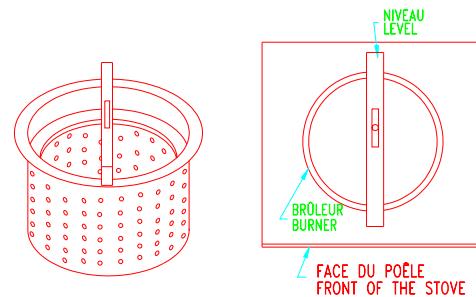

Figure 9B: LEVELLING THE BURNER

FIXATION OF STOVE TO FLOOR

- The unit has to be stabilized in its location using the two fixation brackets. Install the brackets on the two back adjustable legs. (figure 11)
- If the flooring is made of combustible material it would be preferable to install the unit on a non combustible surface covering at least the dimensions of the stove.

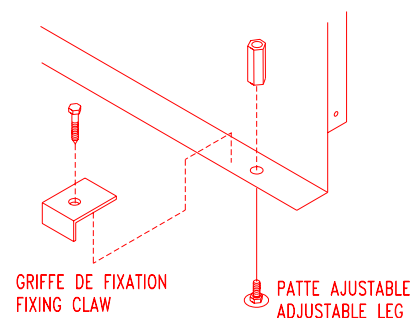

Figure 10: INSTALLATION OF FIXATION BRACKETS

CONNECTING STOVE TO OIL TANK

- Make sure that the tank outlet is 12" (305 mm) higher than the inlet of the carburetor. (Gravity fed)
- Use only copper piping to connect tank to stove.
- Make sure that there is a small slope on the connection from the tank toward the stove.
- A 3" (75 mm) down slope is needed on the tank itself, from the outlet towards the other end of the tank.
- When the tank is installed outdoors, it is preferable to use oil #1, to avoid viscosity problems.

NOTE : THE BAROMETRIC TANK SHALL BE LOCATED SO THAT THE TANK WILL NOT BE EXPOSED TO THE DIRECT RAYS OF THE SUN OR BE ADJACENT TO ANY SOURCE OF INTENSE HEAT.

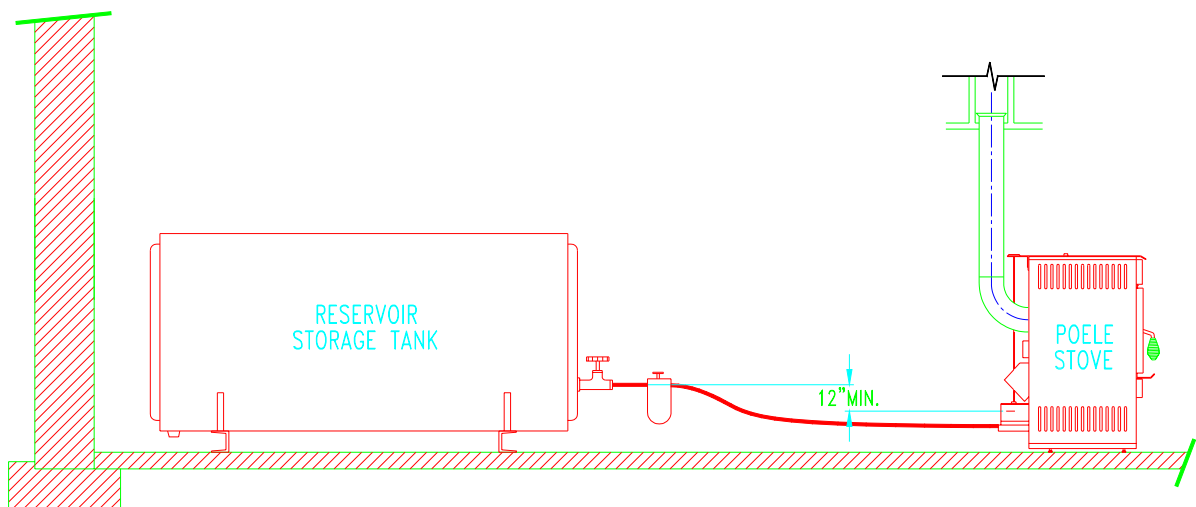

Figure 11 : STOVE AND OIL TANK CONNECTION

ADJUSTING THE DRAUGHT

- Your stove operated with natural draught, created by the ascension of combustion gases in the chimney. This movement creates a siphon effect in the stove and forces ambient air to go in the burner by the holes in its surround. These orifices let air in for combustion.
- For the unit to function properly, it is essential to check the quality of the draught using a draught gauge. The draught is usually measured in inches of water column.
- Check the minimum draught required of the unit on page 1. The draught mentioned has to be reached rapidly at a minimum settling (position #1).
- Depending on the model, the draught can be taken by the orifice on the cooking surface. The measure can also be taken by the orifice on the draught regulator usually plugged by a rubber cap. The orifice on the cooking surface is still the best area.

IMPORTANT : ALWAYS MEASURE THE DRAUGHT WITH ALL VENTILATION EQUIPMENT INSTALLED IN THE HOUSE (RANGE HOOD, BATHROOM FAN, AIR EXCHANGER, DRYER, ETC IN OPERATION.) ref. : standard CAN/CSA B-139 art. 4.1.5.

DRAUGHT REGULATOR

- An excessive draught is as bad as a draught to low.
- The regulator controls the draught when it is excessive (in high winds for exempla).
- If the draught exceeds 0.08 in of water column, you will have to adjust the regulator.
- To adjust the draught you have to screw or unscrew the court weight on the regulator. Regulator open lowers the draught regulator closed increases the draught.

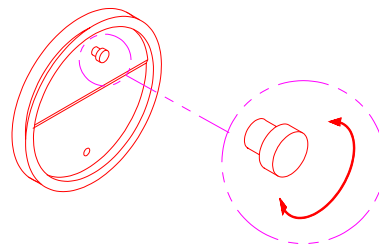

Figure 12: DRAUGHT REGULATOR

THE ONLY RIGHT WAY OF MEASURING THE DRAUGHT IS TO USE A DRAUGHT GAUGE THAT GIVES A READING IN INCHES OF WATER COLUMN. ALL OTHER METHOD (CANDLE, MATCHES, ETC.) ARE UNRELIABLE.

INSTALLATION OF YOUR STOVE HAS TO BE IN ACCORDANCE WITH CAN/CSA B-139 INSTALLATION CODE FOR OIL-BURNING EQUIPMENT IN CANADA AND STANDARD NFPA 31 NATIONAL FIRE PROTECTION ASSOCIATION STANDARD FOR OIL-BURNING EQUIPMENT IN THE U.S..

THE INSTALLATION SHALL BE MADE BY A QUALIFIED PERSON MEMBER OF THE CORPORATION IN FORCE IN YOUR AREA.

OPERATION INSTRUCTIONS

COMBUSTIBLE

- Your stove has been designed to work with oil #1 or #2. **DO NOT USE GASOLINE, CRANKCASE OIL OR ANY OIL CONTAINING GASOLINE.** Drolet Stoves & Fireplaces declines all responsibility regarding damage cause by using other combustibles.
- Make sure to use oil without impurities wich may plug filters and valve's orifice. Impurities only give an improper combustion.

LIGHTING

BEFORE LIGHTING

- make sure that :
 - The tank is full;
 - The isolating valve is open;
 - See that the (3) rings are in the right position. Each of them are stamped A, B and C (figure 13).
 - Make sure that the flow regulating handle is in the « 0 » position (figure 14b).
 - If it's not already done, arm down the valve's lever located behind the stove (figure 14A).
 - Wait for the valve to fill up and let the level stabilize.
- BEFORE ATTEMPTING TO LIGHT YOUR STOVE, MAKE SURE THAT THE FLOW REGULATING HANDLE IS IN THE 0 POSITION.**

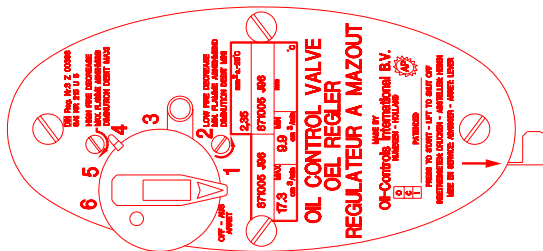

Figure 14B: CONSTANT LEVEL FLOW CONTROL VALVE (CARBURATOR)

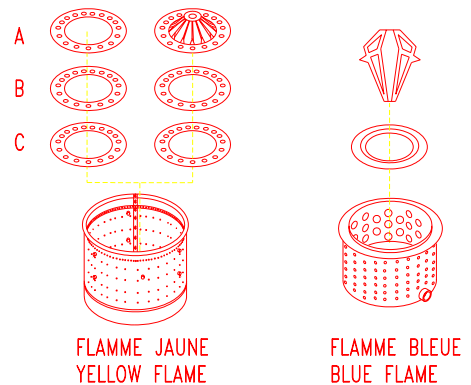

Figure 13: RINGS POSITION

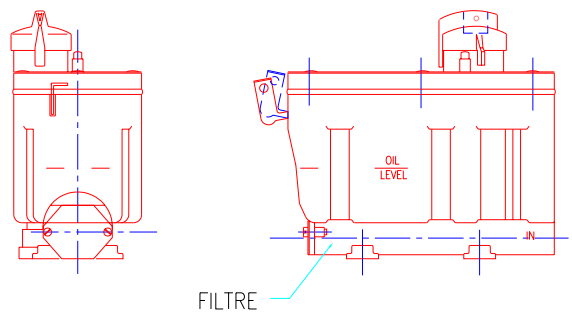

Figure 14B: ARMING / DEARMING FLOW CONTROL VALVE (CARBURATOR).

LIGHTING (CONT'D)

- Place the flow regulating handle on the "1" position, as soon as the oil enters the burner return to "0" position.
- Open the door and pore into the burner 2 to 3 once (75 ml) of lighting gel or wood alcohol.

NOTE : USE OF LIGHTING GEL IS BETTER OF A SAFE IGNITION.

- With a long wood match, ignite carefully and close the door.
- After a couple of minutes (before alcohol goes out) the burner and the chimney are hot, place the flow regulator handle on "1" position.

Note : Do not leave matches or other materials in the burner in order to keep it clean. It allows a better combustion.

IF YOU MISS THE STOVE'S LIGHTING, ALWAYS WAIT FOR THE BURNER TO COOL DOWN TO ROOM TEMPERATURE BEFORE USING BURNING ALCOHOL AGAIN.

IF, FURTHER TO SOME MISOPERATION, THE BURNER IS FILLED WITH IMPORTANT QUANTITIES OF OIL, ALL OF THE OIL MUST FIRST BE REMOVED BEFORE LIGHTING THE STOVE AGAIN.

CHANGING INTENSITY

- Always wait 10 minutes minimum before increasing the flow (between each position). This allows flamme to stabilize and avoid suiting up.
- No waiting is needed to decrease the flow.

TURNING THE STOVE OFF

- Set the flow regulating handle to position "0".
- If you plan to keep the stove off for a long while, it is recommended to disarm the valve's lever and close the tap on the pipe between the stove and your oil tank.

ALWAYS KEEP THE VALVE SHUT OFF WHEN THE BURNER IS NOT OPERATING

MAINTENANCE

ONCE A WEEK :

- Clean the oil inlet tube of the burner with the cleaning tee :
 - Push in the rod of the cleaning tee while turning it;
 - Exerce back and forth operation 2 or 3 times;
 - Pull it back into place to finish the operation.

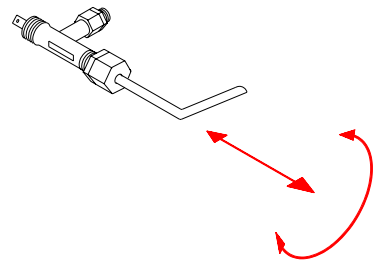

Figure 15 : CLEANING TEE

WHEN YOUR STOVE IS RUNNING, ALWAYS KEEP THE CLEANING TEE LEVER PULLED BACK INTO PLACE.

ONCE A MONTH OR TWO :

- Clean with a metallic brush :
 - The burner's shell;
 - The burner's rings;
 - The burner's catalyist (in blue flame model).

AT THE BEGINNING OF EACH HEATING SEASON :

- Clean the valve and tank filters;
- Inspect the smokebox through the opening of the rear flue outlet;
- Clean the chimney and flue pipe.

MAKE SURE THAT ALL HAND VALVES ARE CLOSED BEFORE CLEANING PROCEDURES.

WHEN NEEDED :

- Clean the glass door.
- The glasses have to be cleaned only when the stove is cold. Use commercial product for this purpose, or a water and vinegar solution.

TROUBLESHOOTING GUIDE

| PROBLEMS | CAUSES | SOLUTION |
|--|---|--|
| <p>ON POSITION 6 (MAXIMUM) THE FLAME IS LONG AND SMOKY, THERE IS SUIT BUILD UPON THE GLASS.</p> <p>ON POSITION 1 (MINIMUM) THE FLAME PRODUCES SMOKE AND SUITS THE GLASS.</p> <p>ON POSITION 1 (MINIMUM) THE FLAME PRODUCES SMOKE AND SUITS THE GLASS.</p> | <p>Position 6 was reached too quickly.</p> | <ol style="list-style-type: none"> 1. Set flow regulating handle to position 1; 2. wait for combustion to stabilize; 3. Progressively increase flow to desired position. <p>NOTE : SEE LIGHTING PROCEDURES.</p> |
| | <p>Maximum flow is too high.</p> | <ol style="list-style-type: none"> 1. Set flow to a lower position; 2. Call a qualified technician to adjust the valve. |
| | <p>Cleaning tee and/or burner are dirty.</p> <p>Orifice of plunger is partially plugged.</p> | <ol style="list-style-type: none"> 1. Activate cleaning tee according to procedures; 2. Schedule at the next shut off to clean the burner. <ol style="list-style-type: none"> 1. Progressively increase flow to position "6"; 2. Push in many consecutive times on the thermostatique regulator bottom to remove dirt form the orifice. <p>NOTE : If the problem persist, you may have to remove and clean out the valve with alcohol. Call your specialized technician.</p> |
| <p>Flow is to low.</p> | <ol style="list-style-type: none"> 1. Slightly increase the flow regulating handle; 2. Call a specialized technician. | |

TROUBLESHOOTING GUIDE (CONT'D)

| PROBLEMS | CAUSES | SOLUTION |
|--|---|--|
| THE FLAME PRODUCES SMOKE, IN ANY POSITION. | Door gasket is not selling properly. | <ol style="list-style-type: none"> 1. Tighten door by turning counterclockwise the door handle; 2. Check if gasket needs to be changed. |
| | <p>The burner orifices are plugged up.</p> <p>Draught is too low.</p> | <ol style="list-style-type: none"> 1. Clean the burner with a metallic brush. 1. Make it checked by a technician. |
| FLAME GOES OUT BY ITSELF. | Oil level in the tank is too low. | <ol style="list-style-type: none"> 1. Fill up the tank. |
| | <p>Air pocket is stocked in the oil line.</p> <p>Oil #2 is used in exterior tank.</p> <p>Partial or total obstruction by impurities in oil line or filters.</p> | <ol style="list-style-type: none"> 1. Call a technician to drain the line; 2. Make sure that the oil line has an adequate slope towards the tank. 1. Use only oil #1 when tank is installed outside. 1. Check filters on tank and valve; 2. Ask a technician if the cleanness of the tank and line is OK. |
| THE STOVE MAKES NOISE, GOES OUT AND LIGHT UP AGAIN. | The stove has been lit while excess of oil was in the burner. | <ol style="list-style-type: none"> 1. Position the flow regulating handle to "0"; 2. Let the stove cool down; 3. Clean the burner if necessary. <p>Note : Never light the stove when the burner is full of oil. Sponge the oil out before lighting.</p> |

SPARE PARTS

After years of use, if you need to replace some parts, please contact your SUPPLIER or one of our Drolet approved DEALERS.

- Give him product data as displayed in your warranty voucher or on your appliance's name plate at the rear. Keep the warranty voucher even after its EXPIRY date.
- Our dealers are in possession of all spare parts nomenclatures and technical data about our products, and will provide you with the spare parts you need and any maintenance intervention within the scope of their professional competence.

| N° | DESCRIPTION |
|----|--------------------------------|
| 1 | Handle |
| 2 | Door |
| 3 | Sealing joint for window panes |
| 4 | Pyrex slivers |
| 5 | Sealing joint for door |
| 6 | Draught regulator |
| 7 | Fan |
| 8 | Fan control |
| 9 | Pan |
| 10 | Valve |
| 11 | Valve support |
| 12 | Valve heat shield |
| 13 | Cleaning tee |
| 14 | Pot liner |
| 15 | Pot |
| 16 | Burner rings |
| 17 | Copper tube |

SPARE PARTS (CONT'D)

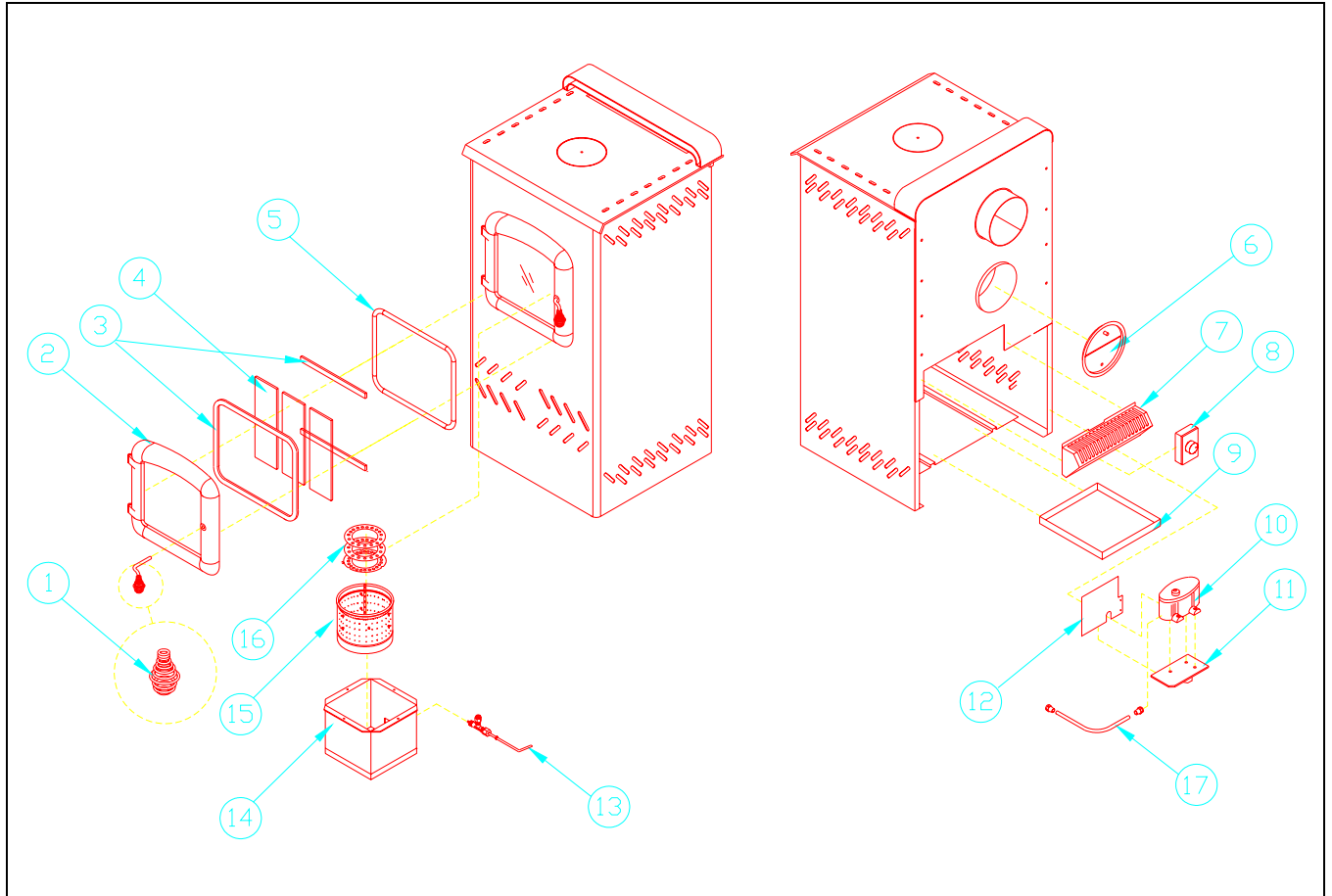

Figure 16: EVEREST EXPLODED VIEW, SPARE PARTS LIST



POÊLES & FOYERS

WARRANTY

The Drolet Stoves & Fireplaces warranty applies to the original buyer only. This warranty may not be transferred to a second person and becomes effective on the date of purchase. Proof of purchase is necessary to validate the warranty and to establish the warranty coverage period.

The warranty is conditional to normal residential use of the product. Any use other than that for which the product was intended will invalidate the warranty. The warranty covers repairs and (or) parts replacement under the terms established by Drolet Stoves & Fireplaces.

| PRODUCT | FIREBOX | PAINT | COMPONENT |
|----------------------|---------|--------|-----------|
| WOOD (EXCEPT HUNTER) | 5 years | 1 year | 1 year |
| GAS | 5 years | 1 year | 1 year |
| OIL | 5 years | 1 year | 1 year |
| GODIN | 5 years | 1 year | 1 year |
| EXTERIOR FIREPLACE | 1 year | N/A | N/A |
| HUNTER | N/A | N/A | N/A |

FIREBOX AND PAINT

The warranty covers manufacturer defects and materials.

COMPONENTS

The following components are covered by the one-year warranty as follows:

- Woodstoves :
Ceramic glass, refractory bricks, gasket, blower, thermodisc and rheostat.
- Gas units :
Ceramic glass, valve, burner, piezo ignitor, pilot, blower and thermodisc.
- Drolet Oil Stoves :
Burner, valve rings, cleaning tee and electrical components.

EXCLUSIONS

This warranty will not cover labor costs or any costs related to damages caused by faulty installation, repairs, abusive use or wrong usage of the product, either by a contractor, a service representative or the buyer himself.

All defects or damages caused by the use of parts other than **Drolet Stoves & Fireplaces** original parts automatically cancels the warranty.

Drolet Stoves & Fireplaces cannot be held responsible of any claims whatsoever, other than the replacement of the parts themselves.

How can we resolve your claims ?

Drolet Stoves & Fireplaces will honor F.O.B. plant (collect) parts replacement for defective parts.

Before sending back products or components to our office, you must be given an authorization number from our representative or your dealer.