

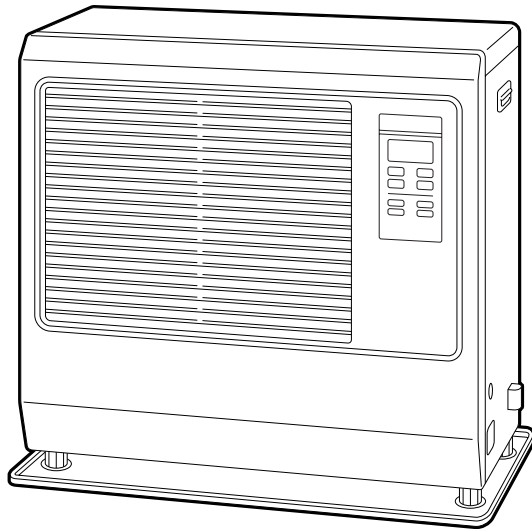

LASER CLEAN HEATING SYSTEM/VENTED HEATER INSTALLATION AND OPERATION INSTRUCTIONS



LASER CLEAN VENTED
MODEL **Laser 730/Laser 730AT**
(Type A)



IMPORTANT

READ AND UNDERSTAND INSTRUCTIONS BEFORE INSTALLING OR USING HEATER.
RETAIN INSTRUCTIONS FOR FUTURE REFERENCE. CHECK LOCAL CODES AND ORDINANCES FOR PERMITTED USE.

CONTENTS

SECTION A:	SECTION G:
Specifications 2	Troubleshooting 8
Safety Features 3	SECTION H:
SECTION B:	Long Term Storage 9
Safety Tips for Operation 4	SECTION I:
SECTION C:	Installation
Fuel Guide 5	Tools Needed for Installation 20
SECTION D:	Standard Installation Parts 20
Operating Controls and Part Names 6	Accessory Parts 22
SECTION E:	Safety Tips for Installation 25
Operation	Installation of Heater and Flue Pipe 26
Before Ignition 9	Permanent Wiring Installation 32
Operation 10	SECTION J:
Turning Heater Off 15	Fueling 33
SECTION F:	
Routine Maintenance 16	

SECTION A: SPECIFICATIONS

Model:	Laser 730/Laser 730AT
Heater Efficiency:	92.4% (1)
Heat Rating:	High - 40,000 BTU/h Med - 27,000 BTU/h Low - 15,000 BTU/h
Fuel Consumption:	High - 0.301 gal/h (1.14 L/h) Med - 0.203 gal/h (0.768 L/h) Low - 0.113 gal/h (0.428 L/h)
Fuel System:	External tank (2)
Fuel Type:	1-K kerosene (ASTM D3699) Low Sulfur No.1 Fuel (ASTM D396 S500) Ultra Low Sulfur Diesel Fuel (ULSD) or Ultra Low Sulfur Heating Oil (ULSHO) (ASTM D975 S15)
Dimensions (W × H × D): (Includes drip tray)	30" × 27-1/2" × 16-3/4" (760 × 700 × 427 mm)
Weight:	75 lbs. (34 kg) Empty
Vent Pipe Hole:	2-3/4" - 3" (7.0 - 7.5 cm) diameter
Maximum Length of Vent Pipe System:	10 ft. (3 m), 3 bends or less
Electrical Rating:	120 Volts AC, 60 Hz Preheat — 260W Burning — 50W
Typical Room Size (3):	1670 square feet (0°F) 2000 square feet (20°F)

(1) Heat and vaporized water are produced by the combustion process of this heater. This rating does not take into account heat loss due to condensation of water vapor.

(2) External tank to be purchased from local suppliers.

(3) 0° F Heat Load = 24 BTU/ft²/hr
20° F Heat Load = 20 BTU/ft²/hr

Room size for which this heater is suitable will vary depending on outside temperature, house insulation, window size, and other factors.

SAFETY FEATURES

Your Laser 730/Laser 730AT is equipped with the following safety features. Please familiarize yourself with these features. When your heater is extinguished due to a safety mechanism, be sure to identify and correct the problem.

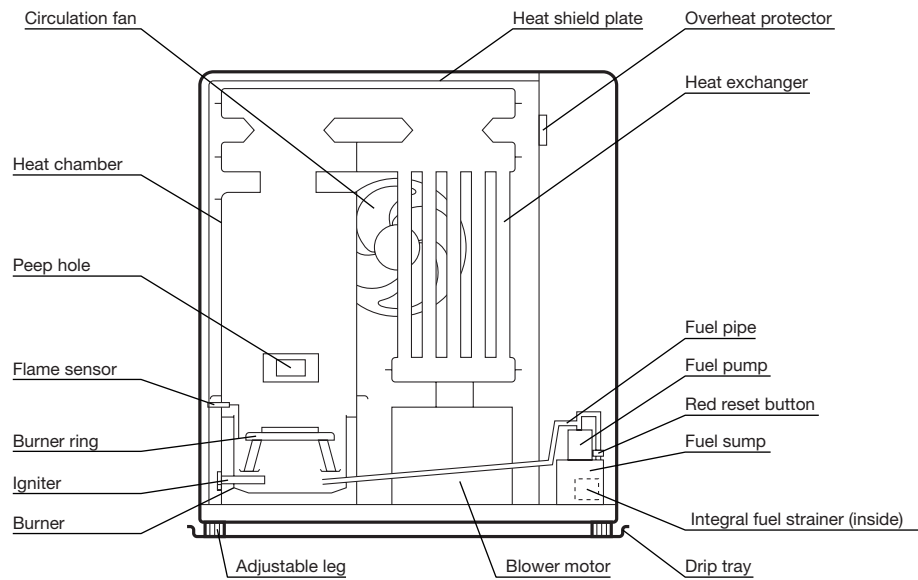

1. Flame Sensor

Heater will automatically stop all operations if ignition fails or if flame fails during combustion, in order to prevent fuel overflow. Error code will be displayed on the digital indicator.

2. Fuel Strainer

Special strainer catches dirt or impurities present in the fuel before it is sent to the burner.

3. Overheat Protector

Automatically stops all operations if heater inside cabinet reaches abnormally high temperature due to motor malfunction or abnormal combustion, in order to prevent fire.

4. Power Failure Recovery System

If power fails during heater operation, heater will automatically reignite and maintain the normal selected temperature, when power resumes.

5. Fully Vented System

Flue pipe system uses outside air for combustion and vents all combustion products to the outdoors.

SECTION B: SAFETY TIPS FOR OPERATION

CAUTION: Heater and vent pipe system must be properly installed before operation.
Please follow instructions under “Installation”, Section I.

1. Never use any fuel other than clear or red colored kerosene (ASTM D3699 1-K Kerosene, ASTM D396 Low Sulfur No.1 Fuel Oil, ASTM D975 Ultra Low Sulfur Diesel (ULSD), or Ultra Low Sulfur Heating Oil (ULSHO)). NEVER USE GASOLINE. Use of gasoline can lead to uncontrollable flames, resulting in destructive fire.

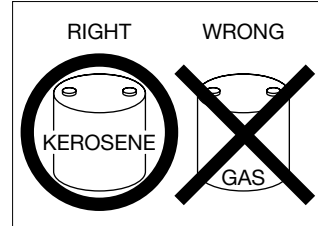

2. Due to high surface temperatures, keep heater away from children, furniture and clothing while in operation (See Page 26).

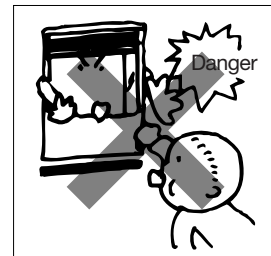

3. To prevent abnormal operation and prolong heater life, be sure to perform routine maintenance (See Pages 16).



4. Never store or transport kerosene in other than a metal or plastic container that is clearly marked, “KEROSENE”, “No.1 FUEL OIL”, “ULTRA LOW SULFUR DIESEL”, or “ULTRA LOW SULFUR HEATING OIL”. Never store fuel in the living space.

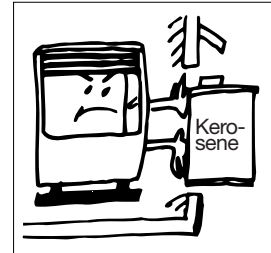

5. Operating Temperature Range
Use heater within the range of temperatures indicated in the right figure.

Point A: If outside temperature -20°F
than room temperature has to be 0°F or above

Point B: If outside temperature -45°F
than room temperature has to be 60°F or above

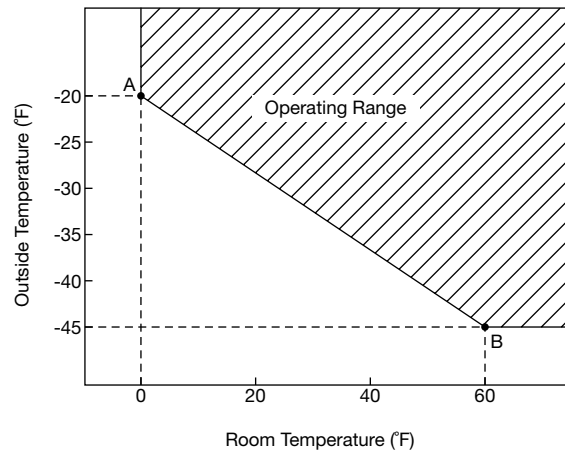

SECTION C: FUEL GUIDE

The Toyostove Laser 730/Laser 730AT is designed for use with ASTM D3699 1-K kerosene, ASTM D396 Low Sulfur No.1 Fuel Oil, ASTM D975 Ultra Low Sulfur Diesel (ULSD), or Ultra Low Sulfur Heating Oil (ULSHO). Use of low-quality fuel will cause burner performance to drop, leading to abnormal combustion and reduced heater life.

Purchase only ASTM D3699 1-K kerosene or ASTM D396 Low Sulfur No.1 Fuel Oil, ASTM D975 Ultra Low Sulfur Diesel (ULSD), or Ultra Low Sulfur Heating Oil (ULSHO) in non-red cans reserved exclusively for kerosene and marked accordingly with the word "KEROSENE", "No.1 FUEL OIL", "ULTRA LOW SULFUR DIESEL", "ULTRA LOW SULFUR HEATING OIL". Always store your fuel in a separate area from where you store gasoline for your power equipment to avoid accidental use of gasoline in your heater.

What to Buy . . .

- ALWAYS :** Clean and high-quality ASTM D3699 1-K Kerosene, ASTM D396 Low Sulfur No.1 Fuel Oil, ASTM D975 Ultra Low Sulfur Diesel (ULSD), or Ultra Low Sulfur Heating Oil (ULSHO).
- ALWAYS :** Fuel free of contaminants, water or cloudiness.
- NEVER :** Gasoline, alcohol, white gas, camp stove fuel or additives.
- NEVER :** Yellow or sour-smelling fuel.

How to Store It . . .

- ALWAYS :** Store in a clean container, non-red in color, clearly marked KEROSENE, No.1 FUEL OIL, ULTRA LOW SULFUR DIESEL, or ULTRA LOW SULFUR HEATING OIL.
- ALWAYS :** Store away from direct sunlight, heat sources or extreme temperature changes.
- NEVER :** In a glass container, or one that has been used for other fuels.
- NEVER :** For longer than six months. Begin each heating season with fresh fuel; discard at the end of season.
- NEVER :** In the living space.

Why It is Important . . .

Good, clean fuel is essential for safe and efficient heater operation. Poor quality or contaminated fuel can cause:

- Excess tar deposits on burner and flue pipe
- Incomplete combustion
- Reduced heater life

Use of a highly volatile flammable fuel such as gasoline can produce uncontrollable flames, creating a severe fire hazard.

Note: The fluidity of Ultra Low Sulfur Diesel and Ultra Low Sulfur Heating Oil becomes worse at temperatures of 21°F (-6°C) and below and can "gel". This condition may cause ignition failure. To prevent congealing it is recommended to use an additive with the fuel. Check with a fuel supply company for the proper additive and mix.

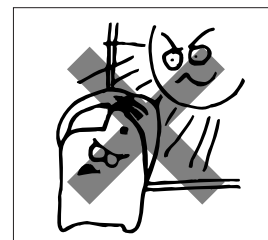
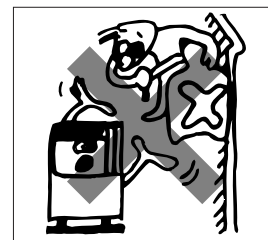

SECTION D: OPERATING CONTROLS AND PART NAMES

Before using the heater, familiarize yourself with the following operating controls and part names.

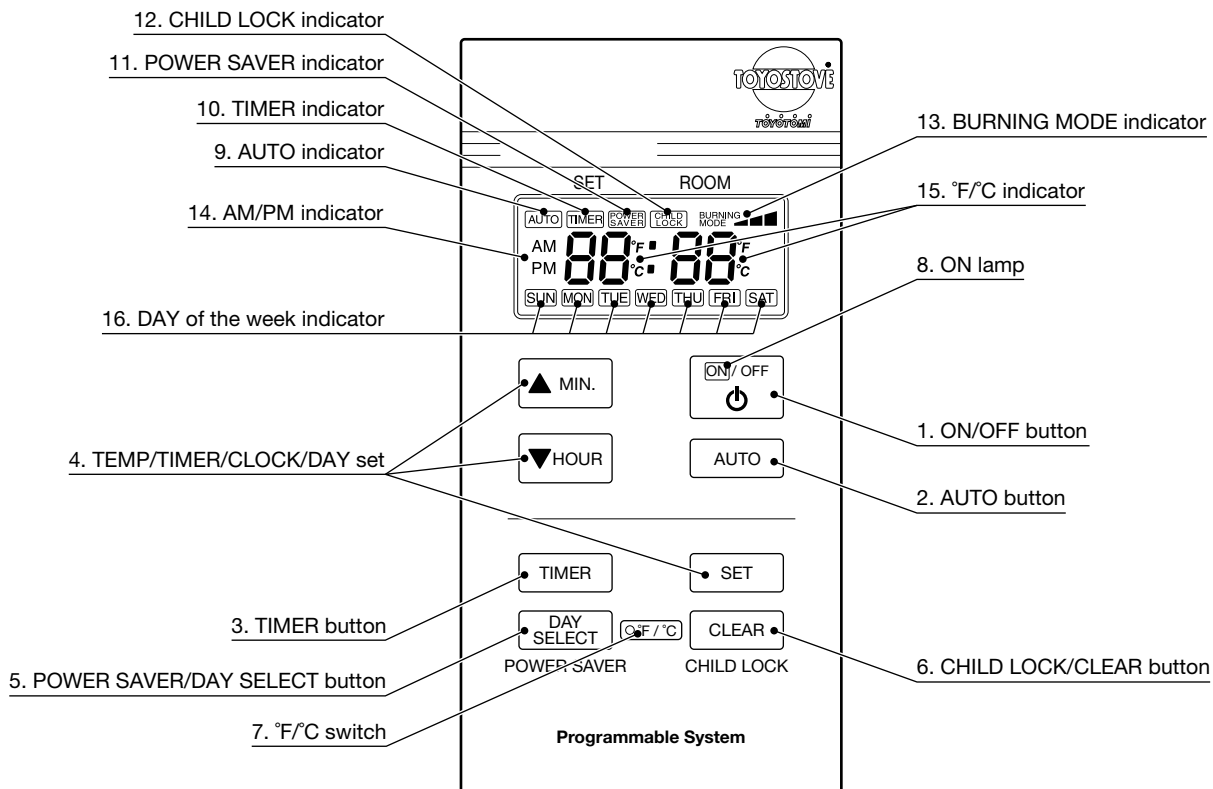
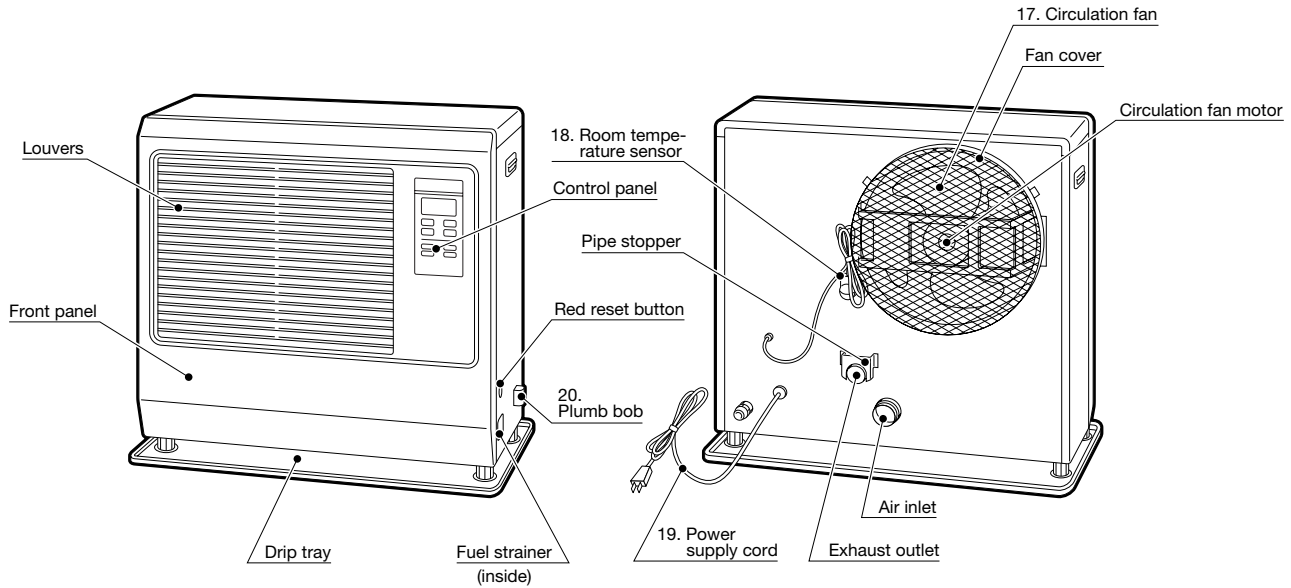

Make a note of your heater's serial number, located on the outside cabinet surface.
Your heater's serial number:

SERIAL NO.

1. ON/OFF button: Main button switch turns heater on and off. When switched on, heater begins operation and combustion starts after preheat period.
2. AUTO button: The button turns weekly timer operation modes on and off which have been programmed into weekly timer.
3. TIMER button: The button turns weekly timer set mode on and off.
4. TEMP/TIMER/CLOCK/DAY set: TEMP/TIMER/CLOCK/DAY set modes can be set by pressing the ▲MIN. or ▼HOUR buttons.
5. POWER SAVER/DAY SELECT button: The button turns POWER SAVER operation mode on and off. When setting weekly timer, the button is used to select a day of the week.
6. CHILD LOCK/CLEAR button: The button turns CHILD LOCK operation mode on and off. When setting weekly timer, the CLEAR button is used.
7. °F/°C switch: C/F toggle switch.
8. ON lamp: Lit – Heater is in operation.
Flashing – Pre-heating and pre-purging.
9. AUTO indicator: Lit – Weekly timer operation is in use.
10. TIMER indicator: Lit – Heater operating in weekly timer set mode.
11. POWER SAVER indicator: Lit – Heater operation in POWER SAVER mode.
12. CHILD LOCK indicator: Lit – Heater operation in CHILD LOCK mode.
13. BURNING MODE indicator: Lit – Heater operation at high, medium or low combustion.
14. AM/PM indicator: Lit – Digital indicator shows current time.
Flashing – Current time can be changed.
15. °F/°C indicator: Lit – Digital indicator shows current temp.
Flashing – Current temp can be changed.
16. Day of the week indicator: Lit – Digital Indicator shows current day or timer day.
17. Circulation fan: Three speed motor supplies high-capacity warm air flow during high combustion for heating room up quickly, and low or medium-capacity warm air flow during low or medium combustion for maintaining comfortable room temperature.
18. Room temperature sensor: Constantly senses room temperature and supplies information to heater so that desired room temperature can be maintained.
19. Power supply cord: For use in 120V, AC electrical outlet.
20. Plumb bob: Allows user to check if heater is positioned evenly.

REF #	PART #	PART NAME
1	20470646	Front panel assembly
2	20479145	Front panel assembly (Laser 730AT)
3	20475804	Carrying handle
4	20479104	Plumb bob
5	20450007	Adjustable leg
6	20478129	Drip tray
7	20479129	Drip tray (Laser 730AT)
8	20470660	Top plate
9	20479160	Top plate (Laser 730AT)
10	20470663	Right side panel
11	20470763	Right side panel (Laser 730AT)
12	20470664	Left side panel
13	20479164	Left side panel (Laser 730AT)
14	20475172	Fan cover
15	20478644	Heat exchanger
16	20475808	Heat chamber assembly
17	20470642	Burner assembly
18	20478643	Burner ring
19	20478026	Fuel nozzle
20	20478383	Fuel nozzle gasket
21	20470218	Igniter
22	17187582	Igniter gasket
23	20479521	Igniter guide gasket
24	20474920	Igniter cover
25	20470611	Primary flame rod
26	20475194	Burner gasket
27	20475850	Burner insulating pad
28	20475831	Peep window
29	20475881	Peep window gasket
30	20474992	Joint packing
31	20475893	Heat chamber gasket
32	20470638	Blower motor assembly
33	20470648	Blower motor assembly with case
34	20478871	Blower motor exhaust fan
35	20475883	Blower motor intake fan
36	20475875	Blower motor case gasket
37	20475878	Rubber mat
38	20475877	O-ring (ø75)
39	20470234	Fuel sump
40	20470619	Fuel pump
41	20470641	Fuel pipe assembly
42	20478550	Fuel inlet strainer
43	20475551	Drain screw with O-ring
44	20475552	Strainer gasket
45	20470612	Main circuit board
46	20470678	Fuse 1 (5A)
47	20470679	Fuse 2 (10A)
48	20470206	High limit switch
49	20470676	Operation panel
50	20470776	Operation panel (Laser 730AT)
51	20474977	Hose band
52	20474975	L-shaped hose
53	20477414	PCB support
54	20474984	Bent joint (L)
55	20470651	Inlet hose
56	20470652	Lever fuel pipe
57	20478669	Circulation fan motor
58	20478373	Thermistor
59	20479891	Flue pipe
60	20474925	Oil catch
61	20475535	Power supply cord
62	20478188	Screw 1X
63	20479885	Outside nozzle gasket
64	20455862	Screw S2
65	20470756	Screw 4D (Laser 730AT)

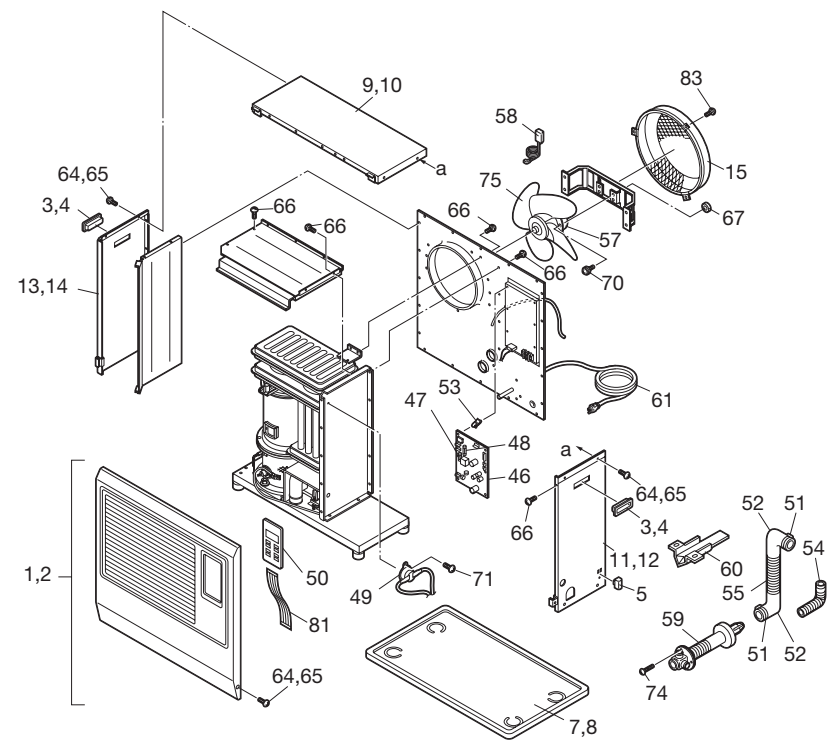

REF #	PART #	PART NAME
66	20470254	Screw 4J
67	20474039	Insulator A
68	20474057	Flange nut
69	20470353	Screw 4P
70	20470355	Screw 4Q
71	20450220	Screw 4I
72	20478090	Screw 1T
73	20476150	Washer E
74	20474985	Screw 4G
75	20475171	Circulation fan
76	20474983	Outlet adapter
77	20478613	Burner mat

REF #	PART #	PART NAME
78	20478366	Air damper (ø25)
79	20478683	Draft tube
80	20474163	Screw I
81	20470675	Ribbon cable
82	20470273	Burner thermistor
83	20470666	Screw 4C
84	20475554	Screw 1Q
85	20474053	Screw F
86	20479957	Nut J
87	20470695	Instruction manual
88	20470699	Carton
89	20470799	Carton (Laser 730AT)

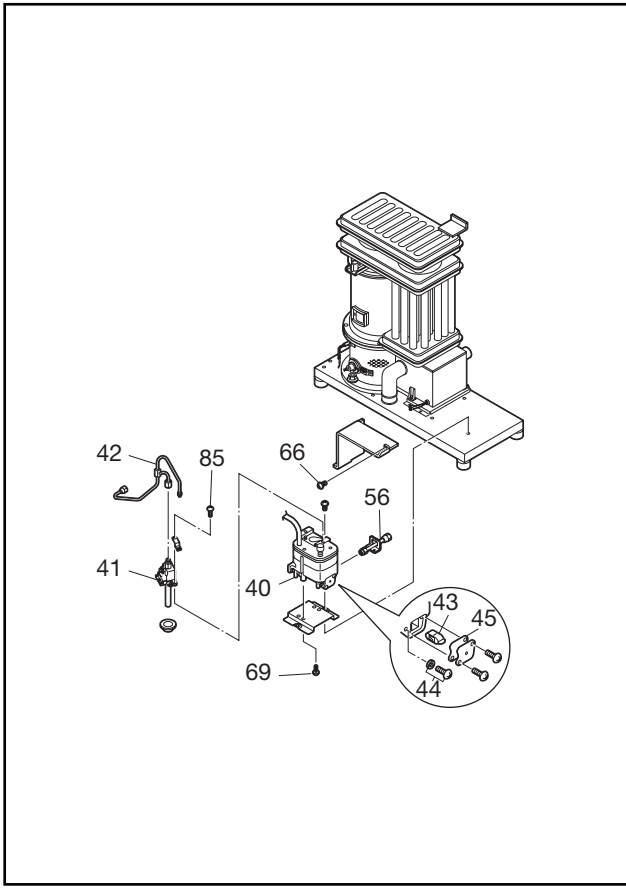
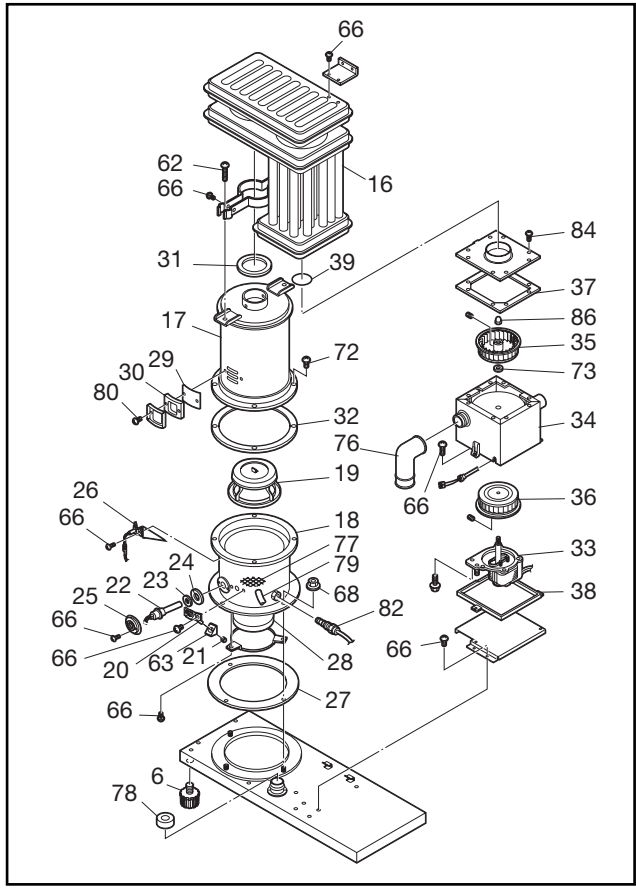

SECTION E: OPERATION

BEFORE IGNITION

1. Open the Valve(s)

Open the valve(s) of the external fuel tank.

2. Start the Fuel flow

If using heater for the first time, press the red reset button in order to send fuel to the fuel sump and release.

Note: Make sure there is no fuel leakage from the fuel line or joints.

Also make sure fuel tank is not too high. See installation instructions.

3. Plug in the Heater

Plug heater into a 120V AC electrical outlet. On digital indicator pre-set "Two Dashes" will be showing.

Note: Do not connect to an outlet shared with other appliances.

4. Set Clock

Important: Clock on the heater must always be set to current time and day.

Note: "HOUR" or "MIN" button will change the time every one (1) unit. Holding the button continuously will cause the time to change rapidly.

Note: In the event of a power failure (more than approx. 30 min.) all clock and day may be cancelled.

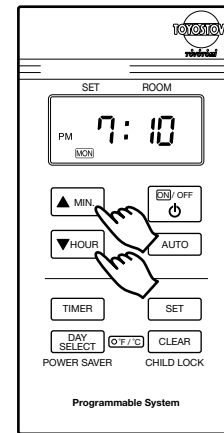
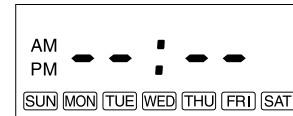
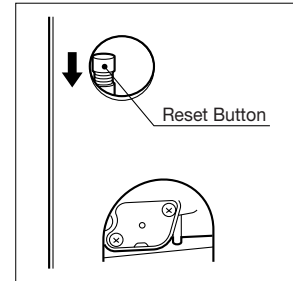

5. Setting of the Time and a Day of the Week.

1) Current time is not set yet. (All signs light.)

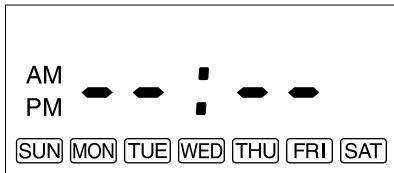

Press the "▲MIN." button or "▼HOUR" button while in not operation. (Power switch is off.)

AM 12:00 is indicated on the display. (All signs except the colon are blinking.)

2) Setting of the current time

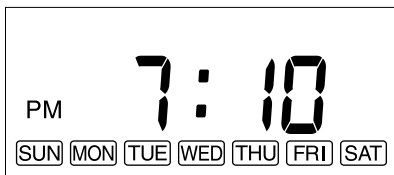

Press the "▲MIN." button to set minutes and press the "▼HOUR" button to set hours.

When pressing the "▼HOUR" button, the sign will change as follows.

"AM 12:00" → "AM 1:00" → ... → "AM 11:00" → "PM 12:00" → "PM 1:00" → ... → "PM 11:00" → "AM 12:00" → ...

When pressing the "▲MIN." button, the sign will change as follows.

"AM 12:00" → "AM 12:01" → ... → "AM 12:59" → "AM 12:00" → ...

Press the "SET" button to complete the set of the current time.

3) Setting of a day of the week

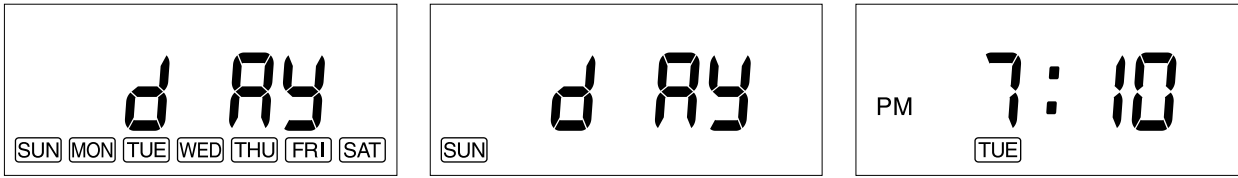

“dAY” sign is shown on the display and all of days of the week will blink.
 Press the “▲MIN.” button or the “▼HOUR” button to set a day of the week. A day of the week will blink. (Initial setting is “SUN”.) The other days of the week will go off. Select a day of the week by using the “▲MIN.” or the “▼HOUR” button. When pressing the “▲MIN.” button, the sign will change as follows.
 “SUN” → “MON” → “TUE” → “WED” → “THU” → “FRI” → “SAT”
 When pressing the “▲MIN.” button at the position of “SAT”, you can hear a beep sound and “SAT” is not changed any more. When pressing the “▼HOUR” button, the sign will change as follows.
 “SAT” → “FRI” → “THU” → “WED” → “TUE” → “MON” → “SUN”
 When pressing the “▼HOUR” button at the position of “SUN”, you can hear a beep sound and “SUN” is not changed any more.
 Press the “SET” button to complete the setting of the days of the week. The current time and a day of the week will show on the display.

Note: If the ON/OFF switch is pressed during setting of the current time and a day of the week after setting the time and a day of the week, the set mode of the current time will terminate and the operation will start. If a day of the week is set, the time is fixed. If a day of the week is not set, the contents of the setting are deleted.

OPERATION

MANUAL OPERATION

Operation of the heater is under the direct control of the user. Heat output will, however, be automatically adjusted in accordance with the room temperature registered by the temperature sensor.

1. Turn Heater ON

- A. Press ON/OFF button to “ON” position. The current room temperature and the set temperature will be shown on the button digital indicator. ON lamp will start to flash and then blower motor and ignition will start. This lamp will continue to flash during the preheating time.
- B. After approx. 3 – 9 minutes ignition will take place. *After ignition, ON lamp will change from flashing to continuous. Circulation fan will turn on after approx. 2 minutes.

Note: *Pre -heating depends on the room temperature.

Room temperature: below 34°F	Approx.	9 minutes
34°F - 61°F	"	6 minutes
over 61°F	"	3 minutes

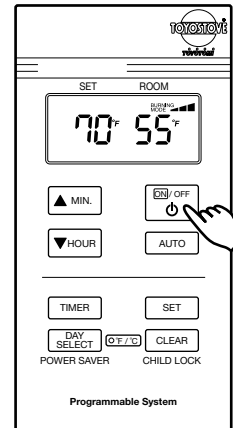

2. Adjusting Room Temperature

A. Press "HOUR" or "MIN." button. °F or °C will start to flash.

Note: "HOUR" or "MIN." button will change the temperature in increment of 2°F (1°C).

B. Press "MIN." for up and "HOUR" for down. Room temperature can be set from 50°F (10°C) to 90°F (32°C). (Initial setting : 56°F (13°C))

C. When room temperature reaches the selected setting, heater will automatically shift to "MED" or "LOW" burning mode to maintain the desired temperature.

When room temperature exceeds the selected setting by approx. 4°F (2°C), the heater will automatically shut off. As room temperature drops, the heater will automatically re-start to maintain the desired temperature.

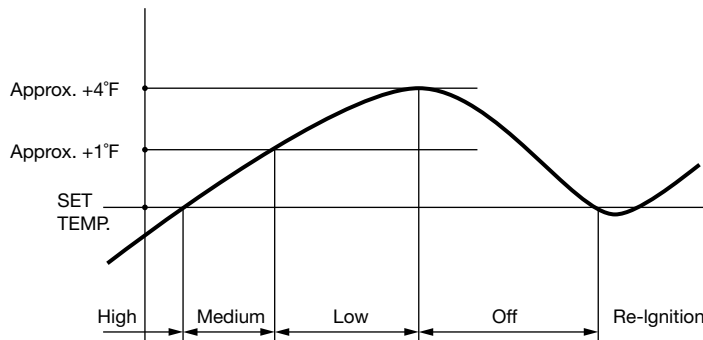
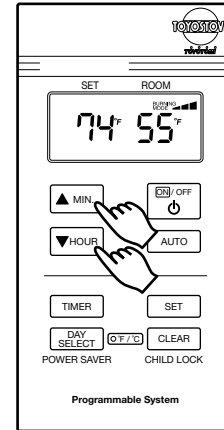

POWER SAVER OPERATION

The Power Saver mode reduces the frequency of ignition actions, to save electric consumption.

Press the POWER SAVER (DAY SELECT) button "ON" while in operation to start the operation of the "POWER SAVER". "POWER SAVER" sign will be shown on the digital indicator.

When the room temperature exceeds the selected setting by approximately 10°F (6°C), the heater will automatically shut off. As the room temperature becomes lower than the selected setting, the heater will automatically re-start to maintain the desired temperature.

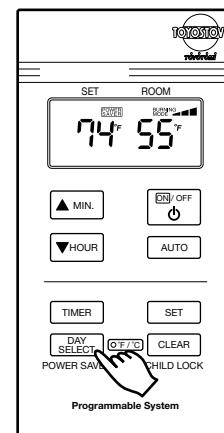

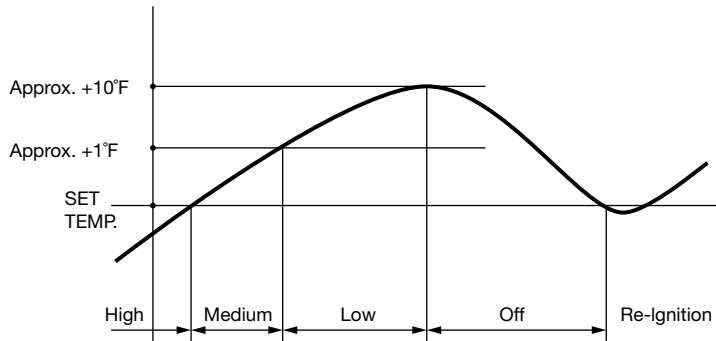

CHILD LOCK OPERATION

Press the CHILD LOCK (CLEAR) button for more than 3 seconds to set the child lock while in operation or not in operation. "CHILD LOCK" sign will be shown on the digital indicator.

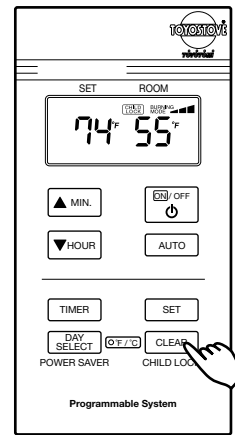

If the ON/OFF Switch is pressed while the Child Lock is on while in not operation, you can hear the beep sound, but the unit does not start. If the ON/OFF Switch is pressed while the Child Lock is on while in operation, the heater will automatically shut down with a beeping sound. "CHILD LOCK" on the digital indicator will flash and "OFF" will be shown on the digital indicator.

To release the warning, press the CHILD LOCK (CLEAR) button for more than 3 seconds.

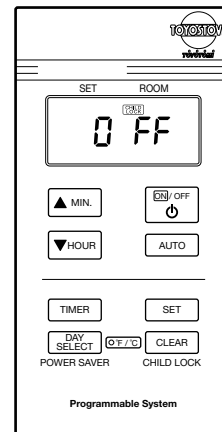

WEEKLY TIMER OPERATION

1. Set the Weekly Timer

Note: The following programs are set at the factory in advance.

Program #	Clock Time	Temp.	Day
P01	AM 6:00	68°F (20°C)	"MON" "TUE" "WED" "THU" "FRI"
P02	AM 8:30	62°F (16°C)	"MON" "TUE" "WED" "THU" "FRI"
P03	PM 5:00	68°F (20°C)	"MON" "TUE" "WED" "THU" "FRI"
P04	PM 11:00	62°F (16°C)	"MON" "TUE" "WED" "THU" "FRI"
P05	AM 7:00	68°F (20°C)	"SUN" "SAT"
P06	AM 10:00	62°F (16°C)	"SUN" "SAT"
P07	PM 4:00	68°F (20°C)	"SUN" "SAT"
P08	PM 11:00	62°F (16°C)	"SUN" "SAT"

After setting the current time and a day of the week, press the "TIMER" button to enter the weekly timer setting mode. The "TIMER" is shown on the display. When the "TIMER" button is pressed during setting of the weekly timer, the "TIMER" sign disappeared and the current clock time and a day of the week are shown on the display.

Note: You cannot enter the weekly timer setting mode, while in operation and AUTO operation mode, on.

1) Select the program number

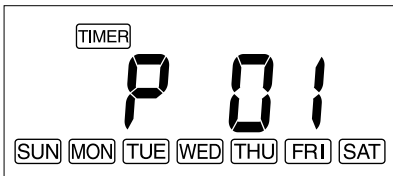

Press the "▲MIN." button or the "▼HOUR" button to select the program number.

The number of program numbers is 30. The non-set program number will flash on the display. In case of the first setting of the weekly timer, "P01" is shown on the display and will blink. In case that the program is already set, the next number of the biggest setting program number is shown on the display. If the program is set until "P30", "P30" is shown on the display and will blink. Even though all program number are set to "P30", if there is any non-set program number, the smallest non-set program number is shown on the display.

When pressing the "▲MIN." button, the sign will change as follows.

"P01" → "P02" → ... → "P29" → "P30"

When pressing the "▲MIN." button at the position of "P30", you can hear a beep sound and "P01" is not changed any more.

When pressing the "▼HOUR" button, the sign will change as follows.

"P30" → "P29" → ... → "P02" → "P01"

When pressing the "▼HOUR" button at the position of "P01", you can hear a beep sound and "P01" is not changed any more.

Example:

In case that "P01" and "P02" programs are set and "P03" is not set, the display shows as follows.

"P01" – solid ⇔ "P02" – solid ⇔ "P03" – flashing 3

In case that "P01" and "P04" programs are set and "P02" and "P03" are not set, the display is indicated as follows.

"P01" – solid ⇔ "P02" – flashing 3 ⇔ "P03" – flashing 3 ⇔ "P04" – solid ⇔ "P05" – flashing 3

When a non-set program number is shown on the display, all of a day of the week will blink.

Press the "SET" button to move to the next step (Set the timer).

The program number memory is cleared by holding the "CLEAR" button continuously for 3 seconds.

2) Set the timer

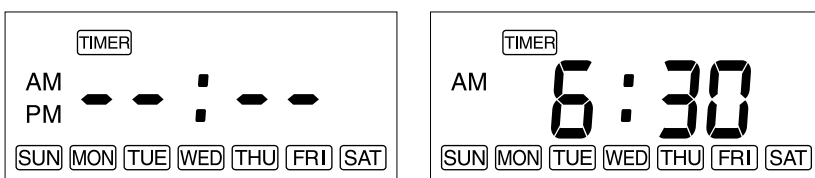

The timer is shown on the display. (In the case that the timer time is not set, dashes are shown on the display.) Press the “▲MIN.” button or the “▼HOUR” button to set timer time. “AM 12:00” will be shown on the display. (The all signs except the colon will blink.)

When pressing the “▼HOUR” button, the sign will change as follows.

“AM 12:00” → “AM 1:00” → ... → “AM 11:00” → “PM 12:00” → “PM 1:00” → ... → “PM 11:00” → AM 12:00” → ...

When pressing the “▲MIN.” button, the sign will change as follows.

“AM 12:00” → “AM 12:10” → “AM 12:20” → “AM 12:30” → “AM 12:40” → “AM 12:50” → “AM 12:00” → ...

Press the “SET” button to complete the setting of the timer time and to move to the next step (Set the temperature of the Program Number).

In case that the “SET” button is pressed when showing the bars sign on the display, you can hear the beep sound and cannot move to the next step.

3) Set the temperature of the Program Number

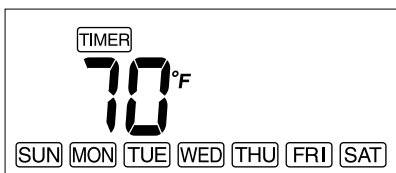

The set temperature “70” will be shown on the display and it will blink.

Press the “▲MIN.” button or the “▼HOUR” button to set the temperature of the program. The “▲MIN.” button or the “▼HOUR” button will change temperature every 2°F (1°C).

Press the “SET” button to complete the set the temperature of the program and move to the next step (Set a day/s of the week for the Program Number).

4) Set a day/s of the week for the Program Number

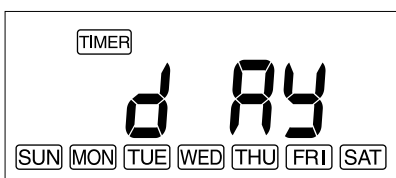

The “dAy” sign will be shown on the display and the “SUN” will blink. Press the “▲MIN.” button or the “▼HOUR” button to set a day of the week, When pressing the “▲MIN.” button, that day is turned on. The day of the week will light and will more to the next day automatically. When pressing the “▼HOUR” button, that day is turned off. The day of the week will go off and will more to the next day automatically. When pressing the “DAY SELECT” button, the display will show the next day of the week without setting. The sign of a day of the week will change as follows.

“SUN” → “MON” → “TUE” → “WED” → “THU” → “FRI” → “SAT” → “SUN” → ...

Press the “SET” button to complete the set of a day of the week of the program and it will go back to the select of the program number. In case that a day of the week is not set, when pressing the “SET” button, you can hear a beep sound and cannot move to the next step.

2. Activate Weekly Timer Operation

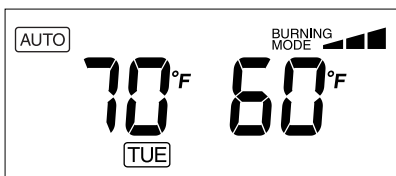

During operation (in ON position), press the “AUTO” button to turn on the weekly timer operation mode. However, if no program are set, you will hear the beep sound and cannot turn on the weekly timer operation mode. Press the “▲MIN.” button or the “▼HOUR” button to change the set temperature. However, if the next program starts, the temperature will be changed to the temperature of the next program.

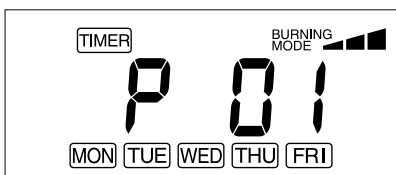

During operation, press the “TIMER” button to enter the weekly timer set mode (Select the program number). If the “TIMER” button is pressed during the setting of the weekly timer set mode, the weekly timer set mode is turned off. Change of setting is applied as soon as the AUTO operation is turned on.

MANUAL COMBUSTION

Important: This feature is for testing purpose only!

This heater can also be kept burning at desired combustion mode (High, Medium or low) manually, regardless of room temperature.

1. Press the “▲MIN.” button and “▼HOUR” button at the same time for more than three (3) seconds when ON / OFF button is “ON”.
2. P1, P2 or P3 will be displayed on the Digital Indicator;
 - P1 = Low mode
 - P2 = Medium mode
 - P3 = High mode

Then select desired combustion mode by pressing “▲MIN.” or “▼HOUR” button. “▲MIN.” button changes combustion mode to higher, “▼HOUR” button changes combustion mode to lower.

3. To clear, press the “▲MIN.” button and “▼HOUR” button at the same time for more than (3) seconds until normal temperature display returns.

AUTOMATIC CLEANING MODE

When the heater has been burning continuously for two hours at its highest setting, the burner will automatically start an auto clean procedure. The display will show the auto cleaning code $EL:05$ running back to $EL:01$. The procedure takes 5 minutes to clean the burner automatically, while the heater will burn at its lowest setting. When the burner is clean again, the heater will automatically switch back to the highest setting again.

TURNING HEATER OFF

Press ON/OFF button to “OFF” position. ON lamp will flash and will go out. Circulation fan and blower motor continue to run for approx. three (3) minutes to cool down the heater. Make sure ON lamp goes out when the fan stops.

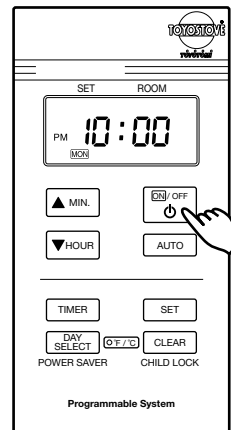

SECTION F: ROUTINE MAINTENANCE

CAUTION: Be sure to turn off and unplug heater before performing any checks or cleaning.

CAUTION: Allow heater to cool completely before cleaning or maintenance.

FOR OPTIMUM HEATER PERFORMANCE, THE PARTS SHOWN BELOW SHOULD BE CLEANED REGULARLY:

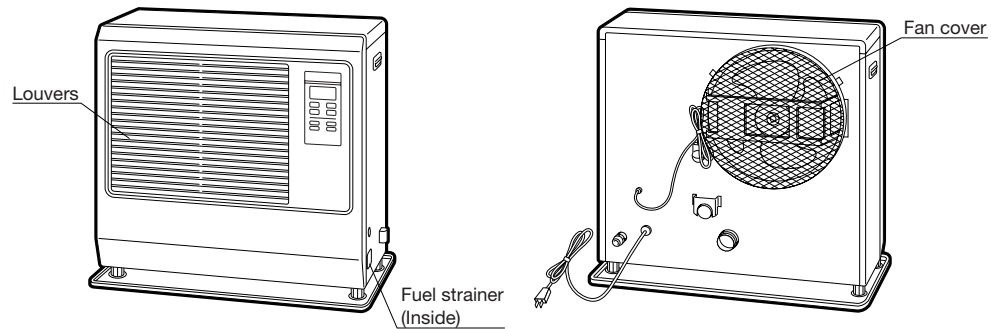

1. Clean Louvers (ONCE A MONTH)

Dust and stains should be wiped off louvers with a damp cloth.

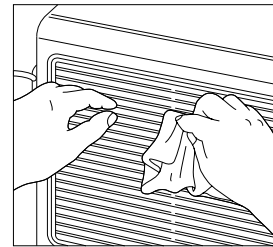

2. Clean Circulation Fan Cover (ONCE A MONTH)

Remove dust and/or pet hair from the cover on the back of the heater. Use a vacuum to remove any dust or pet hair.

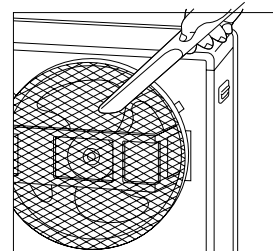

3. Check for Fuel Leaks (REGULARLY)

Make it a habit to check for any signs of fuel leakage along the fuel line and at all joints. Fuel leaks may lead to risk of fire, and should be corrected immediately.

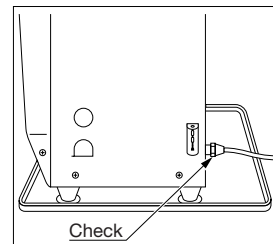

4. Check Flue Pipe Area (ONCE A MONTH)

Check the flue pipe joint to make sure connection is firm. Use a vacuum cleaner to remove any dust or pet hair.

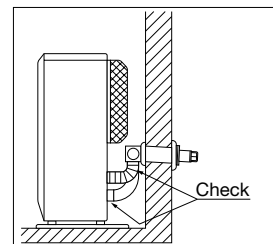

5. Clean Fuel Strainer (ONCE A SEASON)

The strainer of the fuel sump should be cleaned once a season and before starting the heater at the beginning of each season.

- (a) Close the valve closest to the heater.
- (b) To catch the fuel which will drain out, set the Oil catch below the Strainer cover, with a small container under it.
- (c) Loosen the two screws from the Strainer cover and remove.
- (d) Remove the strainer and wash with kerosene or fuel oil.
- (e) Return the strainer to its original position. Replace strainer cover and screw to secure.
- (f) Wipe away any spilled fuel.
- (g) Open the valve in the fuel line. Check for fuel leakage.

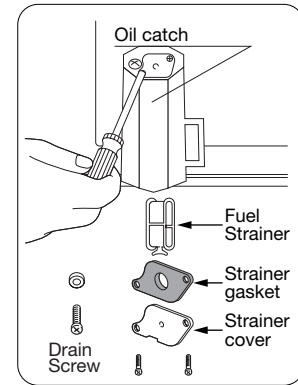

Note: At the end of each season unscrew the drain screw to remove all the remaining fuel from the fuel sump. Be sure to follow procedure A and B listed above and replace Drain screw.

6. Recommended Periodic Maintenance

As a state-of-the-art furnace, your heater requires periodic inspection and service by an authorized technician to insure optimum, trouble free performance. This inspection should include: a combustion check; flue pipe check; burner assembly check; cleaning all necessary parts and replacing gaskets as needed. Please ask your authorized Toyostove dealer for details and scheduling. When using *Ultra Low Sulfur Diesel (ULSD)* or *Ultra Low Sulfur Heating Oil* the heater should be serviced at least every two years because the distillation of *ULSHO* is heavier than 1-K Kerosene and No. 1 Fuel Oil. When using 1-K Kerosene or Low Sulfur No. 1 Fuel Oil your heater can be serviced less frequently.

AUTOMATIC IGNITER CLEANING SYSTEM

When the heater is on and clock is set (see "set Clock" on page 9), it will automatically stop and clean the igniter every day at 2:00 AM and will display "CL" on the digital indicator. After the cleaning mode is finished the heater will automatically re-ignite and continue to burn again.

The igniter cleaning mode helps prolong the igniter life.

MANUAL IGNITER CLEANING SYSTEM

Heater will clean igniter for ten (10) minutes manually.

1. When ON/OFF switch is "OFF", press the "SET" button and "CLEAR" button at the same time for more than three (3) seconds.
2. Display will appear "CL:10" on Digital Indicator. Cleaning will begin and end without any additional input.

Note: Cleaning igniter is important to prolong igniter life. It is recommended that the igniter be cleaned once a month if the time is not set.

SECTION G: TROUBLESHOOTING

NOTE BEFORE REQUESTING FOR REPAIR AND SERVICES

The following symptoms are normal during operation of the heater.

	CONDITION	REASON
When heater is started or extinguished.	White smoke or smell at initial use after purchase.	Machine oil or dust burns off of the surfaces the surfaces of the burner or heat exchanger.
	Flames flashing for a few minutes after ignition.	The burner is cold and igniter is kept running for a while after ignition.
	Occasionally makes "cracking" noise when heater is ignited or extinguished.	Expansion and shrinkage of metal parts when they are heated or cooled.
	Warm air will not blow as soon as ignited.	To prevent uncomfortable cool air from coming out at the beginning, the circulation fan start up is delayed.
	Audible chugging sound from fuel pump when started first time or after running out of fuel.	Air is in the pump. However, noise should stop within 1 minute.*
When heater is in operation.	"Ticking" noise.	Noise of fuel pump in operation. Normal.
	Part of the heat chamber or the heat exchanger is heated to a cherry red color.	Normal.
	Occasional yellow flickering in blue flame.	Normal.

*If sound from fuel pump does not decrease and heater shuts off, check:

1. Push red reset button on fuel sump once. DO NOT hold down.
2. Insure that all valves are open and filter is clear.
3. Insure external fuel tank has fuel and filters are clean.

Should problems arise during operation or ignition, use this chart to determine the cause and the proper steps to take. Be sure to unplug heater and allow to cool completely before taking corrective measures.

In the event that heater should extinguish itself, without any action or your part, you should look to the digital indicator for any of the following error codes.

ERROR CODE	CAUSE	SOLUTION
E- 0	Power failure (low voltage, unstable frequency)	Check power source.
E- 23	Primary flame (Flame sensor) is malfunction and/or dirty	Consult your dealer for cleaning and inspection.
E- 6	Fuel line malfunction	Consult your dealer.
E- 2	Out of fuel / no flame	Check fuel gauge on fuel tank; refuel.
E- 2 / E- 6	Flue pipe blockage or leak	Consult your dealer. / Check flue pipe.
E- 8	Blower motor malfunction	Consult your dealer.
E- 12	High limit switch activated	Clean circulation fan filter and remove any obstructions, allow your heater to cool completely and re-ignite.
E- 13	Burner thermistor failure	Consult your dealer.
E- 13	Flue pipe blockage or leak	Check flue pipe. / Consult your dealer.
E- 22	Ignition failure three times	Consult your dealer.

SECTION H: LONG TERM STORAGE

At the end of each heating season, or when you do not plan to use your heater for an extended period, the following procedures are recommended.

1. As the end of the season approaches, calculate your fuel purchases so that you can use up all the fuel you have on hand. When fuel is stored for over six months, its quality may deteriorate. The use of such fuel will have an unfavorable effect on heater operation.
2. If your heater needs any service or repair, now is the time to call your dealer and get it done before storage. That way your heater will be ready for immediate use when the next heating season begins.
3. If you plan to store your heater in place,
 - (a) Disconnect power supply.
 - (b) Close the main tank valve.
 - (c) Remove all fuel from the fuel sump and clean the fuel strainer.
 - (d) Wipe off any stains or dust on heater with a damp cloth, then wipe once again using a dry cloth.

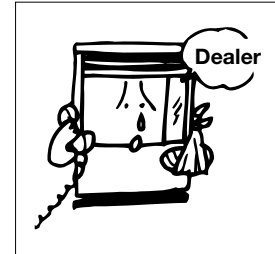

4. To store heater in another location,
 - (a) Disconnect heater.
 - (b) Close the main tank valve.
 - (c) Remove all fuel from the fuel sump and clean the fuel strainer.
 - (d) Disconnect fuel line and flue pipe from the heater.
Note: Fuel remaining in the fuel line may flow out when fuel line is disconnected. Have a container ready to catch drainage.
 - (e) Remove any soot accumulated in the flue pipe using a brush and/or vacuum cleaner.
 - (f) Wipe off any stains or dust on heater with a damp cloth, then wipe once again using a dry cloth.
 - (g) Put the heater in the original shipping box, and store in a dry place. If original shipping box is not available, cover the heater completely with a large plastic bag to protect from dust during storage.
 - (h) Plug exhaust and air intake openings of the flue pipe by using optional caps.
(Part #20479845 and #20474949)

TRANSPORTATION

Take the following measures to avoid fuel leakage during the transportation of the heater.

- Always move the heater in an upright position.
- Always drain fuel from the fuel sump before transportation.

SECTION I: INSTALLATION

TOOLS NEEDED FOR INSTALLATION

Tool

Phillips Head Screwdriver
 Electric Drill
 Hole Saw, 2-3/4 to 3" diameter

Use

Installation of flue pipe, etc.
 Drilling hole in wall for flue pipe
 Making hole in wall for flue pipe

STANDARD INSTALLATION PARTS

The following standard installation parts are enclosed with heater. For alternate installation methods, you may need to purchase additional accessories which are available from your TOYOSTOVE dealer. See "Accessory Parts", page 22.

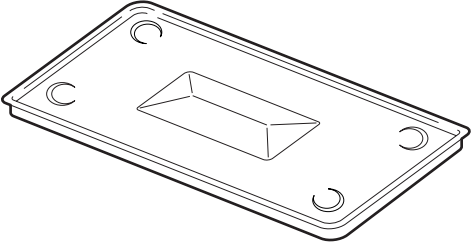
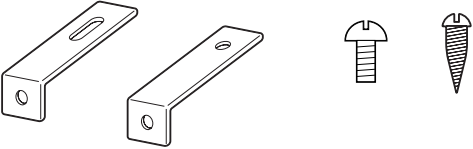
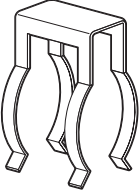
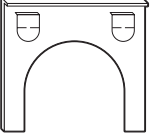
 <p>Drip Tray (1) (PART #20478129 for Laser 730) (PART #20479129 for Laser 730AT)</p>	 <p>Wall Brackets (2 sets) (PART #20474962)</p>
 <p>Pipe Holder (1) (PART #20474963)</p>	 <p>Pipe Stopper (1) (PART #20474964)</p>

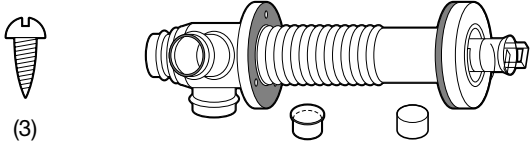
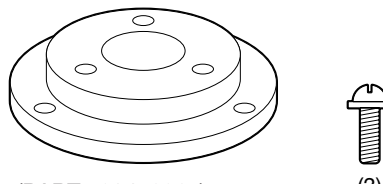
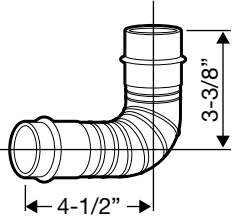
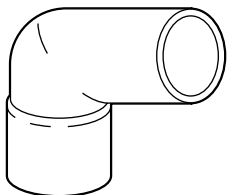
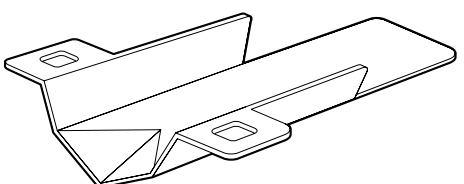
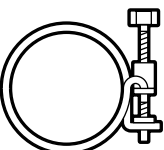
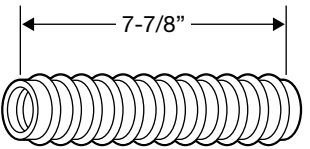
 <p>(3) Flue Pipe (1) (PART #20479891) Exhaust Air Cap (1) (PART #20479845) Intake Air Cap (1) (PART #20474949) Screw 4G (3) (PART #20474985)</p>	 <p>Spacer (1) (PART #20478967) Screw M (3) (PART #20474272)</p>
 <p>Bent Joint (L) (1) (PART #20474984)</p>	 <p>L-Shaped Hose (2) (PART #20474975)</p>
 <p>Oil Catch (1) (PART #20474925)</p>	 <p>Hose Band (2) (PART #20474977)</p>
 <p>Inlet Hose (1) (PART #20470651)</p>	

ACCESSORY PARTS

The following accessory parts are available for use in non-standard installation of the Laser 730/Laser 730AT. After giving careful consideration to your desired heater and flue pipe locations and fueling system, consult your TOYOSTOVE dealer to purchase the necessary accessory parts.

Important: Use only genuine TOYOSTOVE parts for your heater. Use of unauthorized, generic or other brand parts can severely reduce performance and safety, and will void factory warranty.

Accessory	Part No.	Application
Extension pipe kit (L)*	20479898	Extends pipe system from 61-3/4 to 78-3/4"
Extension pipe kit (M)*	20479897	Extends pipe system from 22-1/2 to 39-3/8"
Extension pipe kit (S)*	20479896	Extends pipe system from 12-5/8 to 19-5/8"
L-Shaped exhaust joint*	20479861	For 90 degree bend in exhaust pipe
Fuel lifter pump Model OPT-91UL	20477500	Used to lift fuel to heater when fuel tank is located underground or outdoors in a position lower than the heater. With automatic recovery.
Pressure reducing valve	10005099	See Note on page 34.

* Total length of extension pipe between heater and flue pipe must be no greater than 10 ft. and no more than three bends may be used in extension pipe.

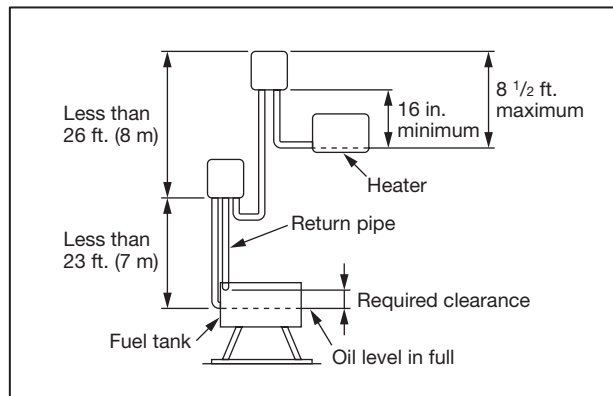
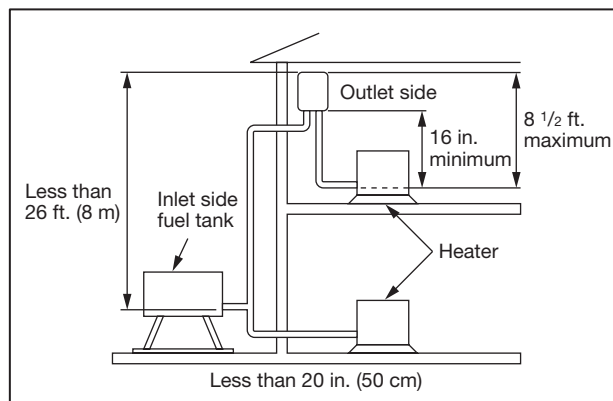
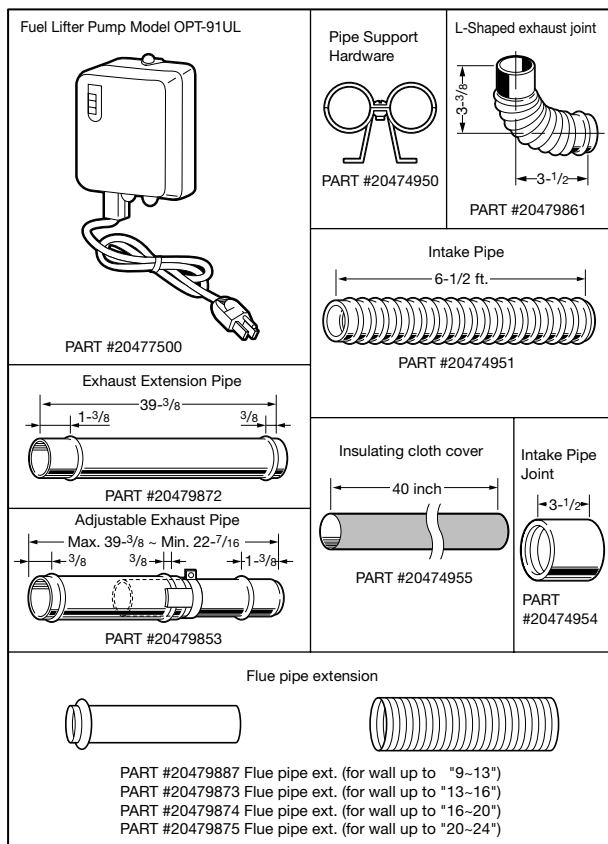

EXTENSION KIT

Extension Pipe Kit (L) PART #20479898

No.	Name of Part	Q'ty
①	Adjustable Exhaust Pipe Max. 39-3/8~ 22-7/16	1
②	Exhaust Extension Pipe (long, 39-3/8 inch)	1
③	Intake Pipe (80 inch)	1
④	Insulating cloth cover (40 inch)	2
⑤	Pipe Holder	2
⑥	Pipe Support Hardware	3 sets
⑦	L-Shaped Exhaust Joint	1

Figure 1

When using the "Extension pipe (L)" extension kit, the distance between the heater exhaust pipe connection and the flue pipe connection must be at least 63-5/8 inch but no more than 80-1/2 inch. (See Figure 1 for reference.)

INSTALLATION WITH EXTENSION PIPE KIT (L)

NOTE: Use "L"-shaped Exhaust Joint if necessary.

Extension Pipe Kit (M) PART #20479897

No.	Name of Part	Q'ty
①	Adjustable Exhaust Pipe Max. 39- ³ / ₈ - Min. 22- ⁷ / ₁₆	1
②	Intake Pipe (40 inch)	1
③	Insulating cloth cover (40 inch)	1
④	Pipe Holder	1
⑤	Pipe Support Hardware	2 sets
⑥	L-Shaped Exhaust Joint	1

Figure 2

When using the "Extension pipe (M)" extension kit, the distance between the heater exhaust pipe connection and the flue pipe connection must be at least 25-⁵/₈ inch but no more than 42-¹/₂ inch. (See Figure 2 for reference.)

Extension Pipe Kit (S) PART #20479896

No.	Name of Part	Q'ty
①	Adjustable Exhaust Pipe Max. 19- ¹¹ / ₁₆ - Min. 12- ⁵ / ₈	1
②	Intake Pipe (20 inch)	1
③	Insulating cloth cover (40 inch)	1
④	Pipe Holder	1
⑤	Pipe Support Hardware	1 sets
⑥	L-Shaped Exhaust Joint	1

Figure 3

When using the "Extension pipe (S)" extension kit, the distance between the heater exhaust pipe connection and the flue pipe connection must be at least 15-³/₄ inch but no more than 22-³/₄ inch. (See Figure 3 for reference.)

SAFETY TIPS FOR INSTALLATION

Follow the safety tips below when planning the installation of your Laser 730/Laser 730AT.

1. Intake and exhaust flue pipe openings must be fully exposed to outside air. Do not vent into chimney, garage, basement under the floor, or into any enclosed area.

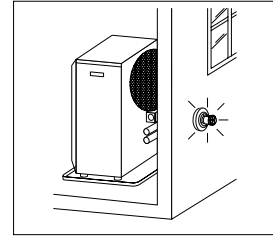

2. Do not install flue pipe in close proximity to other objects or materials (See page 26).

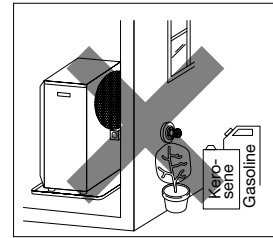

3. Before making a hole in your wall for the flue pipe, make sure the area is free of electrical wires, gas pipes and other obstacles.

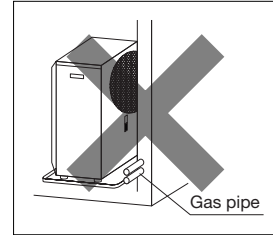

4. Do not install flue pipe where it will be exposed to heavy snow collected leaves or strong drafts.

Important:

In areas of heavy snow falls, ground surface clearance must be increased according to average snow falls.

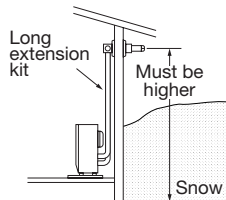

Important:

In open area with strong wind, a wind break may be necessary.

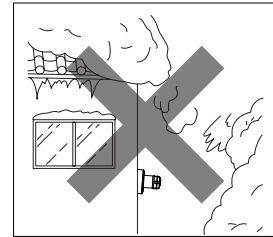
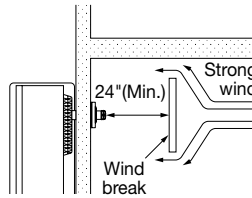

5. Do not install the flue pipe down from the heater.

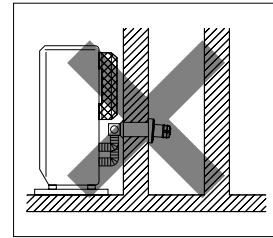
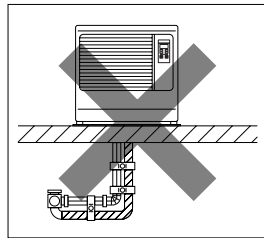
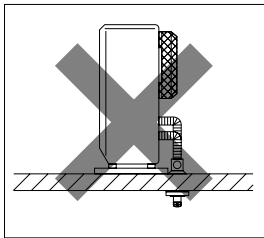

6. Total length of extension pipe between heater and flue pipe must be no greater than 10 ft. and no more than 3 bends.

NOTE: When using extension pipes always cover the exhaust pipe with the insulating cloth cover.

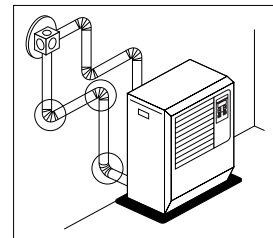

7. B-Vent shall not be used in the vent system.
For all prescribed heater installations, the flue pipe must always be installed in a horizontal position.

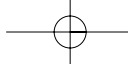

INSTALLATION OF HEATER AND FLUE PIPE

IMPORTANT: Check and comply with all state and local codes that may apply to vented heaters before beginning installation.

NOTE: This heater is designed to be used at altitudes up to 3,000 ft. above sea level.
For use at altitudes higher than 3,000 FT. and up to 6,000 FT., adjustments to the heater must be made.
Consult with your dealer.

MINIMUM CLEARANCE TO COMBUSTIBLE AND NONCOMBUSTIBLE CONSTRUCTION

1. Select heater location. Allow clearances as indicated below between heater and all other materials.
(See Fig. 1)

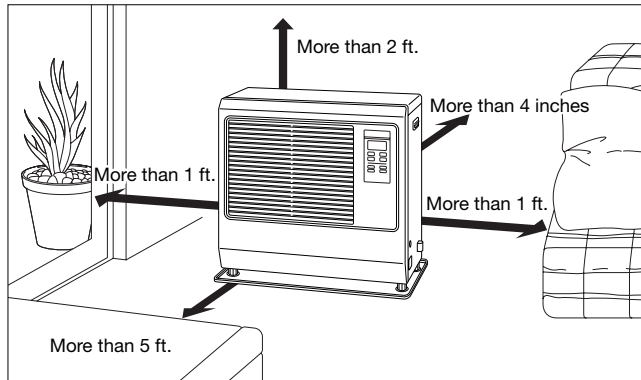

Fig. 1

Note: These clearances are necessary to allow proper circulation and to have heater work effectively.

2. Make sure that the outside area to where the flue pipe will reach is clear of any objects.
(See Fig. 2 & 3)

CAUTION! The standard flue pipe installation, as shown in Fig. 2, is for wall thickness from 4 in. to 9 in. ONLY.
Note: For wall thickness more than 9 in., refer to page 22 for available flue pipe extensions.
Note: The flue pipe can be installed through any standard building materials.

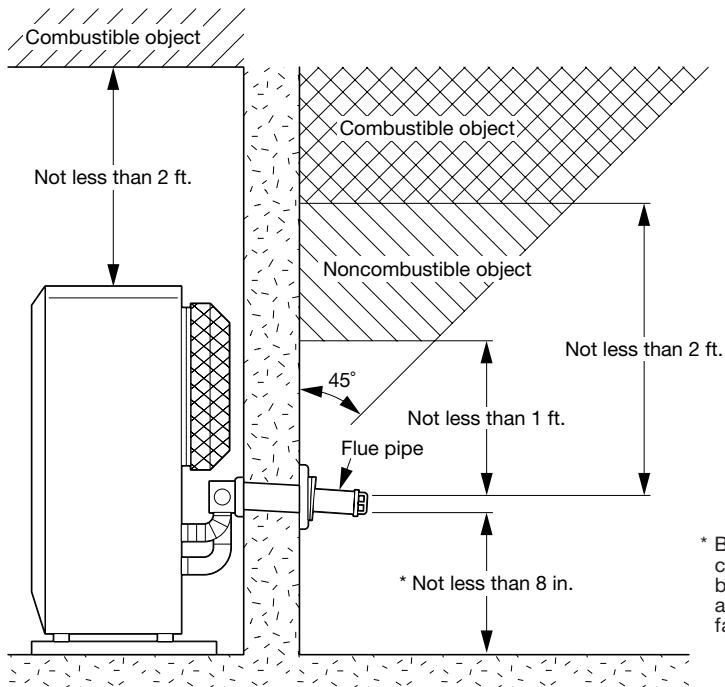

Fig. 2

<Standard Flue Pipe Installation>

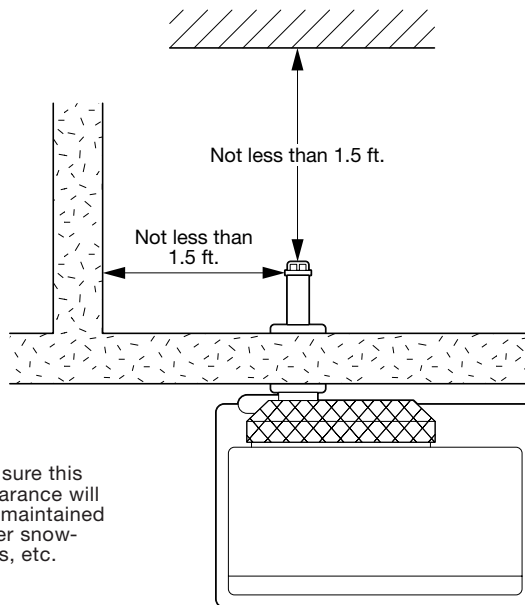
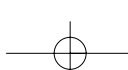

Fig. 3

* Be sure this clearance will be maintained after snow-falls, etc.



3. For standard installation, use the template enclosed with the heater to position the hole for the flue pipe. Tack or tape template to the wall at the desired position (See Fig. 4).

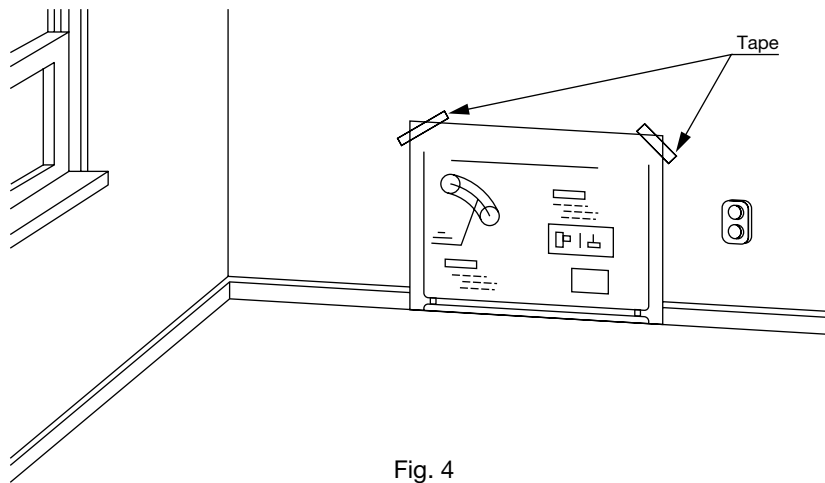

Fig. 4

NOTE: Heater should be installed on a sturdy floor that is level and flat.

4. Cut the hole for the flue pipe from inside the room. Use a 2-3/4 to 3" diameter hole saw attached to an electric drill (See Fig. 5). The opening on the inside wall should be slightly higher than the outside opening (approximately 1/4") so that the flue pipe will slope slightly downward (approximately 2 degrees) after it is installed (See Fig. 6). This will enable the draining of condensed moisture from the flue pipe to the outside and prevent rain or snow entering from outside after installation.

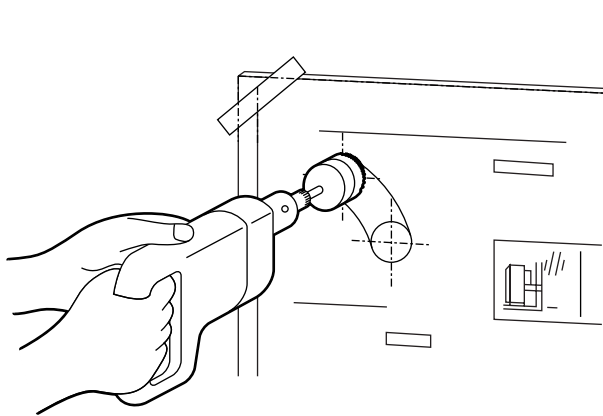

Fig. 5

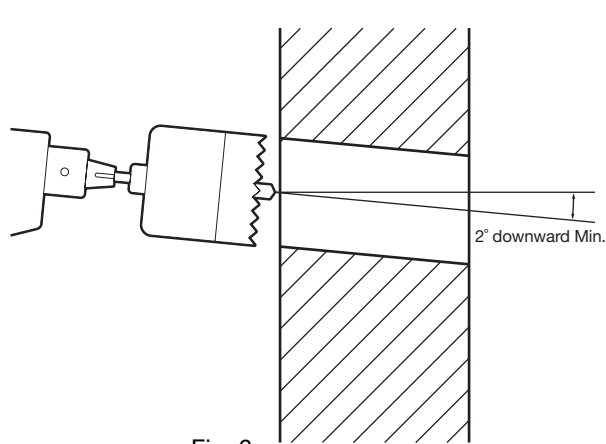

Fig. 6

NOTE: After the cutting of the hole is completed, remove the template from the wall.

5. Install the inner flue pipe.

- a. For wall thickness 5-3/16" to 9"

From inside the room, insert the inner flue pipe through the hole. Make sure the arrow on the inner flue pipe is pointing up. Secure the inner flue pipe to the wall with the three wood screws. (See Fig. 7.)

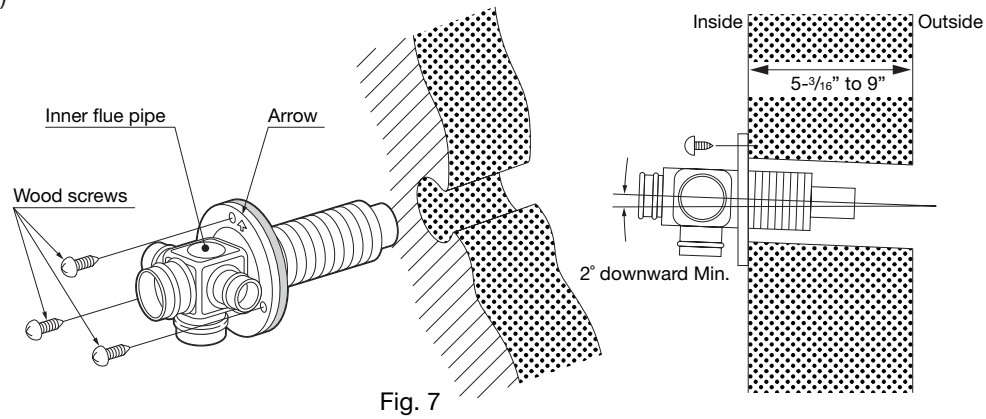

- b. For wall thickness 4" to 5-3/16"

In the event that the wall is too thin, use the spacer as indicated in Fig. 8.

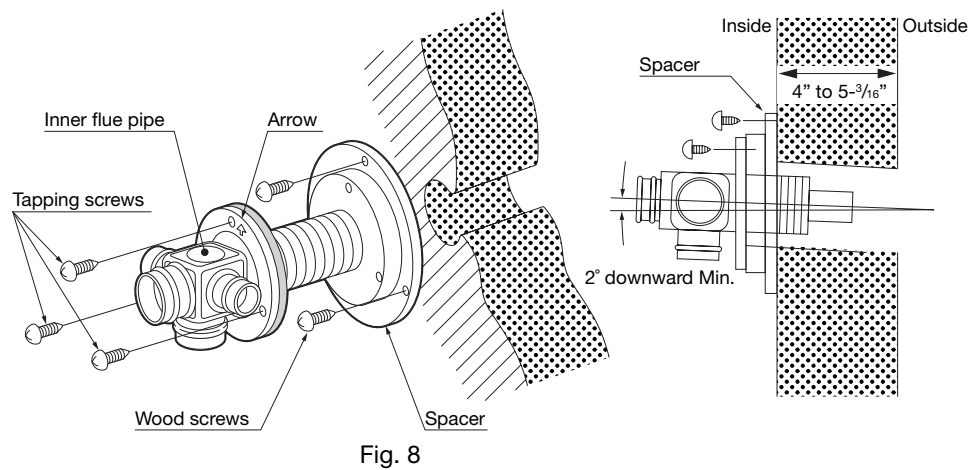

- c. From outside, insert the outer flue pipe through the hole. Secure the outer flue pipe to the wall by turning it clockwise. This locks the two halves together (See fig. 9).

IMPORTANT: Make sure the arrow on the outer flue pipe flange is pointing up.

Make sure to secure the outer flue pipe well. (A-part shown in Fig. 9)

Check inside flue pipe for insulation and remove if any.

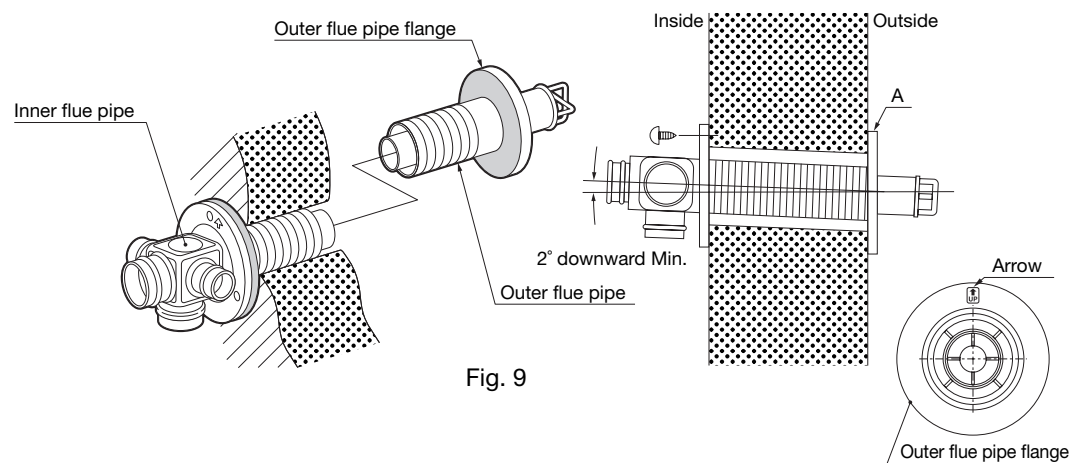

6. Insert the bent joint to the exhaust opening of the flue pipe. Cut the inlet hose for desired length if necessary. Attach the L-shaped hose to each end of the inlet hose and attach the L-shaped hose to the intake opening of the flue pipe. Secure the L-shaped hose to the intake opening with the hose band. Plug the unused exhaust (metal cap) and intake (rubber cap) opening with the caps provided with the heater. Make sure the caps fit tightly onto the opening (See Fig. 10).

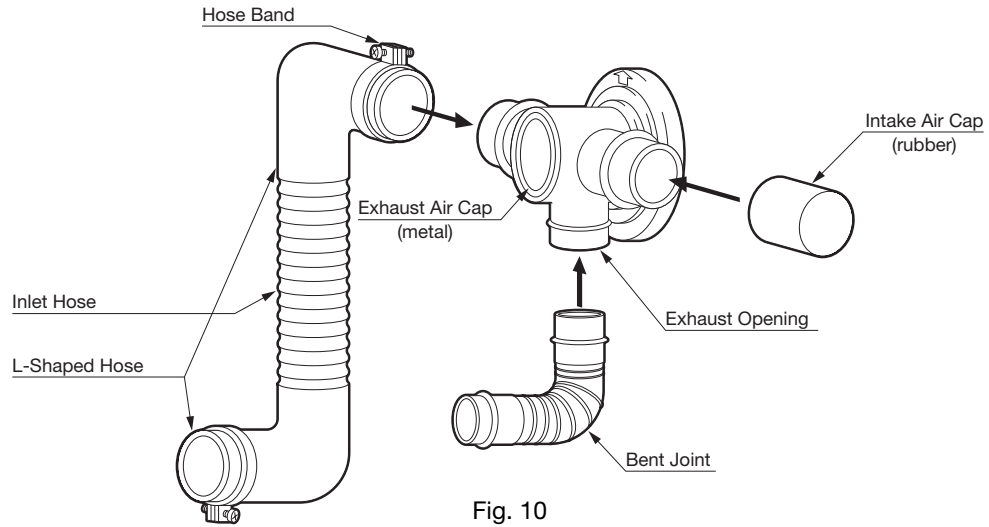

Fig. 10

NOTE: If the inlet hose is not smoothly inserted into the L-shaped hose, apply water with soap suds to the inlet hose. Do not use grease on air intake.

7. Move the heater into position. Connect the bent joint to the exhaust outlet opening (upper opening) and attach the L-shaped hose to the intake inlet opening. Make sure all connections are tight (See Fig. 11).

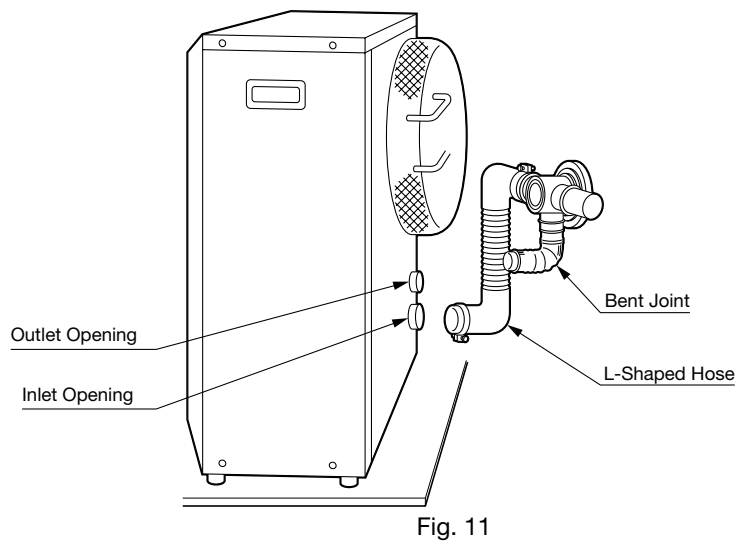

Fig. 11

8. Secure the L-shaped hose to the intake inlet opening with the hose band. Secure the bent joint to the flue pipe with the pipe holder (If the extension pipe is used, also attach the pipe holder to the connection of the bent joint and the extension pipe). Secure the bent joint (or the extension pipe) to the exhaust outlet opening by sliding the pipe stopper in the exhaust opening bracket (See Fig. 12).

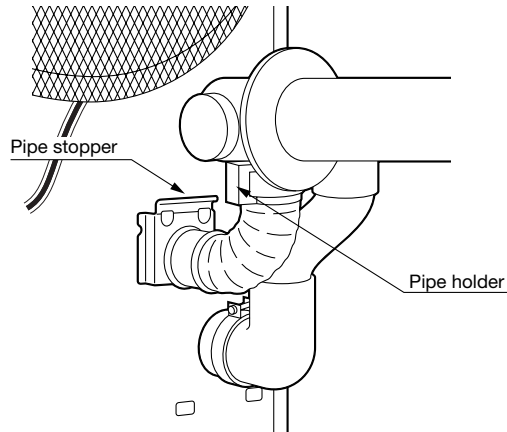
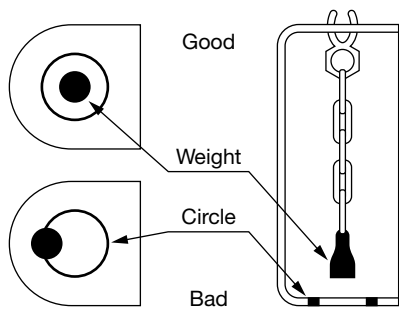

Fig. 12

9. Make sure the position of the heater is level by using the plumb bob located at the right side of the heater. The plumb bob weight should be within the circle. If the plumb bob weight is not within the circle, adjust the heater legs until the plumb bob weight is within the red circle (See Fig. 13 & 14).



Plumb bob as viewed from above

Fig. 13

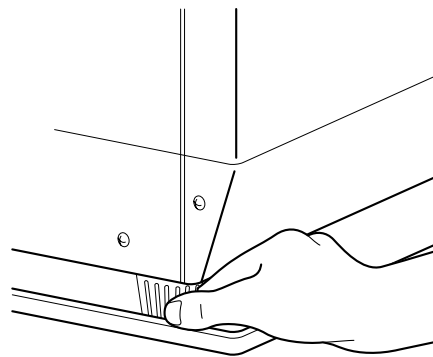

Fig. 14

10. A room temperature sensor is provided with approx. eight (8) feet long extension wire. It is located on the rear of the cabinet. Make sure that the extension wire is not touching the exhaust pipe. The room temperature sensor can be installed either with the self adhesive tape on the back or with a wood screw provided with the sensor depending on the type of surface chosen for installation.

NOTE: Choose a location for the sensor that is not in the path of direct sunlight, drafts or the flow of warm air from the heater.

(a) Self Adhesive Tape

Peel off the protective tape on the back of the sensor and expose the adhesives. Place the sensor on the desired location on the wall and press down.

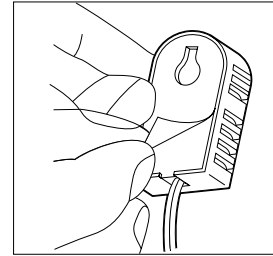

(b) Wood Screw

Screw down the wood screw provided with the heater into the desired location on the wall. Hook the back of the room temperature sensor.

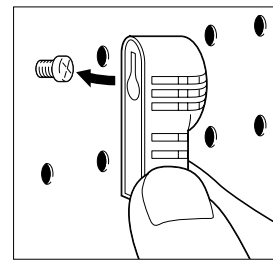

11. After installation is completed, secure heater to the wall with the wall brackets provided with the heater. Make sure the heater is parallel to the wall (See Fig. 15).

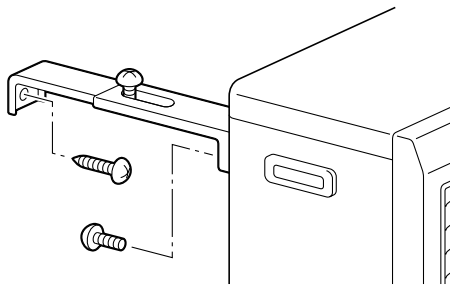

Fig. 15

12. Before ignition, recheck the following:
- All connections are tight and firm.
 - The heater and the flue pipe areas are free of any materials.
 - The heater is level and parallel to the wall.

PERMANENT WIRING INSTALLATION

WARNING: MAKE SURE POWER SUPPLY CORD IS DISCONNECTED TO AVOID ANY ELECTRIC SHOCK BEFORE SERVICING. ELECTRIC SHOCK MAY CAUSE SERIOUS INJURY. INSTALLATION SHOULD BE CONDUCTED BY A LICENSED ELECTRICIAN.

Step 1.
Disconnect power supply cord from power source.
Remove two (2) screws on the front panel of the heater.

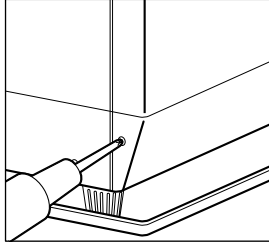

Step 4.
Squeeze strain relief with the adjustable pliers to remove plastic bushing from the power supply cord bracket.
Remove the power supply cord.

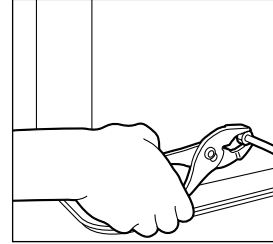

Step 2.
Disconnect ground wire (green wire) from the power supply cord bracket.

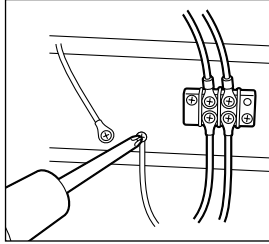

Step 5.
Insert the power supply cable from junction box and connect ground wire to the power supply cord bracket and power wires to the terminal.

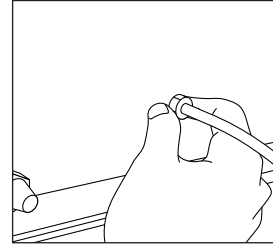

Step 3.
Disconnect two power supply wires from right side of the terminal.

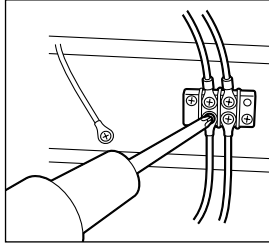

Step 6.
Replace the front panel and secure the two (2) screws.

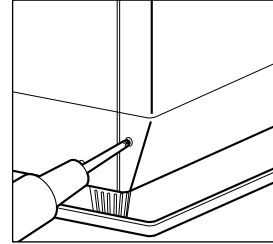

NOTE: Emergency power supply and use of 12V DC batteries with an inverter. Consult your dealer before attempting to use a battery/inverter system to provide power for your Laser heater. These units require true sine wave power for proper long-term operation. Some types of modified or block sine wave inverters will cause damage to the electrical components of the heater. Several inverter manufacturers offer true sine wave inverters which should operate the unit without any problems if properly sized and configured. If you have any questions about appropriate power supply, consult your authorized TOYOSTOVE dealer.

SECTION J: FUELING

WARNING: Use only ASTM D3699 1-K kerosene, ASTM D396 Low Sulfur No.1 Fuel Oil, ASTM D975 Ultra Low Sulfur Diesel (ULSD), or Ultra Low Sulfur Heating Oil (ULSHO). NEVER USE GASOLINE. Use of gasoline can lead to uncontrollable flames resulting in destructive fire.

Laser 730/Laser 730AT FUEL SYSTEM OPTIONS

• Large Capacity External Tank

Tank must be purchased separately and installed by a qualified fuel supply technician.

EXTERNAL TANK INSTALLATION

NOTE: External tank installation must comply with National Fire Protection Association Code NFPA 31, CSA Standard B139, the Installation Code for Oil Burning Equipment, or locally applicable codes. Check with local building officials.

The following instructions should be followed for installation of a large capacity, gravity-fed external fuel tank.

- Installation height of tank's fuel outlet should be at least 16 in. above floor surface upon which heater rests.
- To avoid excess fuel pressure to heater, top of fuel tank should be no more than 8-1/2 ft. above floor surface upon which heater rests.
- Fuel tank should be located at least 6 ft. away from all heat sources.
- 3/8" OD copper tubing should be used for fuel line.
- To prevent air locks in fuel line, fuel line should be smooth with no U-shaped or sharp bends.
- Install a UL listed fuel filter at the fuel tank outlet (**it is highly recommended to use an in-line small mesh size filter with water block, e.g. 10 micro filter**). Shut-off valves should also be installed on the fuel line and connected the tank as illustrated on page 34.

NOTE: An additional shut-off valve installed next to the heater will minimize fuel to be drained should heater have to be disconnected. If the valve is on interior side, a fusible link type is recommended.

1. Be sure all external tanks have an operating vent.
2. Be sure to observe the maximum and minimum tank heights as specified.

NOTE: If the maximum height from the top of the fuel tank to the bottom of the heater exceeds 8-1/2 ft., a fuel pressure reducing valve, preset at 2.5 psi, is required.

Pressure Reducing Valve Part#10005099 has 3/8 in. (N.P.T.) inlet and outlet female openings to accept the fuel line fittings.

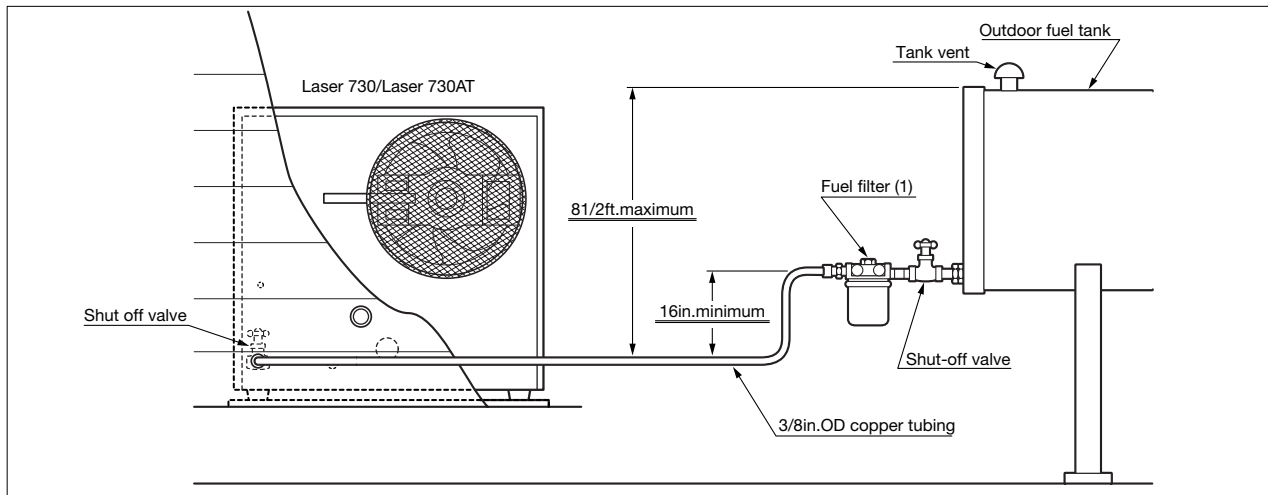

NOTE: Please check local codes for permitted use.
(1) 15 or less Micron Filter is recommended.

CUSTOMER'S RECORD

PROGRAM MANAGEMENT TABLE

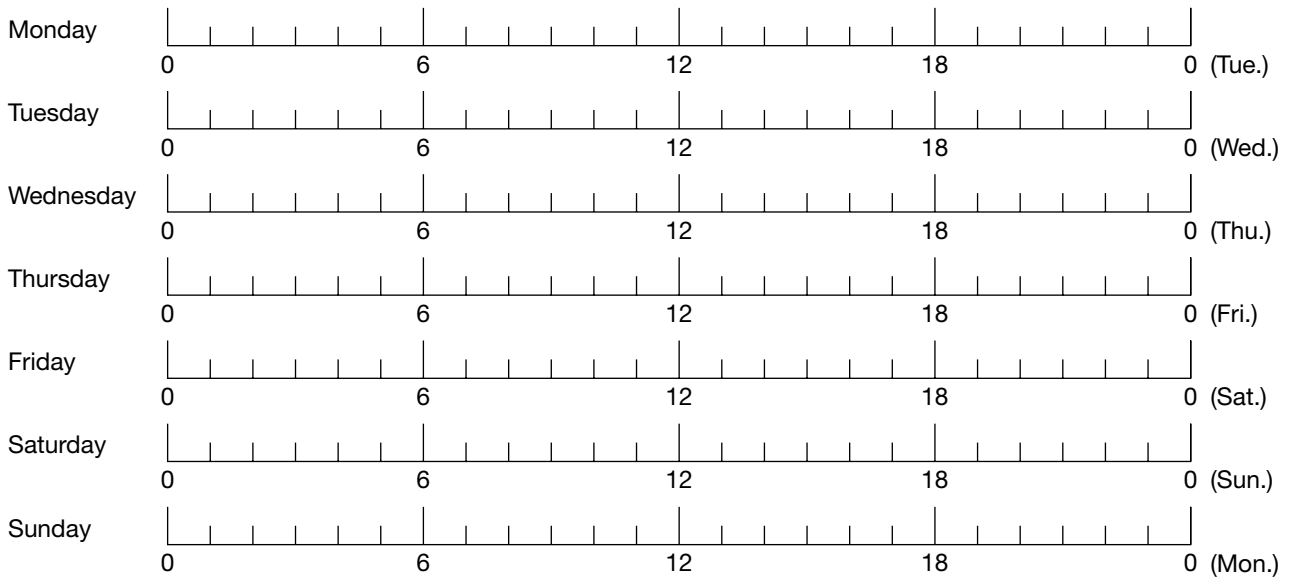

PROGRAM #	TIME	TEMPERATURE	DAY
1			
2			
3			
4			
5			
6			
7			
8			
9			
10			
11			
12			
13			
14			
15			
16			
17			
18			
19			
20			
21			
22			
23			
24			
25			
26			
27			
28			
29			
30			

LIMITED WARRANTY

TOYOTOMI U.S.A., INC. ("TOYOTOMI") warrants each product and any parts thereof sold by it to be free from defects in materials or workmanship under normal use and service for TWELVE (12) MONTHS* from the date of delivery to the original purchaser at retail subject to the following terms and conditions :

WHAT IS COVERED : Product or any parts thereof which are defective in materials of workmanship.

WHAT IS NOT COVERED :

(1) This warranty does not extend to any defect due to the negligence of others: failure to install, operate, or maintain unit in accordance with instructions (Installation and Operation instructions are furnished with each new unit); unreasonable use; accidents; alteration, use of unauthorized or non-standardized TOYOTOMI parts and accessories; electrical malfunction, i.e., as resulting from large power surges, short circuit, etc.; incorrect installation; use of any fuel other than that specified in owner's manuals; or repair by anyone other than a service facility specified by TOYOTOMI.

(2) Normal wear and tear of parts, including hoses, wires, burner mats, fuel nozzles, filters and accessories.

(3) This warranty does not cover shipping costs.

WHO IS COVERED : The original purchaser at retail.

WHAT WE WILL DO : TOYOTOMI will either repair or replace, at its option, all defective parts free of charge that are covered by this limited warranty on a carry-in basis, to your nearest authorized dealer or distributor of TOYOTOMI.

WHAT YOU MUST DO FOR WARRANTY SERVICE : You must return the defective Product or part to any authorized dealer or distributor of TOYOTOMI with this LIMITED WARRANTY and a copy of your bill of sale or credit card charge receipt or other documents evidencing the date of the Product's delivery, if service is not available locally, please contact our CUSTOMER RELATIONS DEPARTMENT at :

TOYOTOMI U.S.A., INC.
604 Federal Road, Brookfield, CT 06804
(203)775-1909

THE FOREGOING EXPRESSES ALL OF TOYOTOMI'S OBLIGATIONS AND LIABILITIES WITH RESPECT TO THE QUALITY OF PRODUCT FURNISHED BY IT. ALL OTHER WARRANTIES, EXPRESSED OR IMPLIED, INCLUDING THE WARRANTIES OF MERCHANTABILITY OR FITNESS FOR A PARTICULAR PURPOSE ARE DISCLAIMED. TOYOTOMI SHALL NOT BE LIABLE FOR THE LOSS OF USE OF THE PRODUCT, INCONVENIENCE, LOSS OR ANY OTHER DAMAGES, DIRECT OR CONSEQUENTIAL ARISING OUT OF, THE USE OF, OR INABILITY TO USE, THE PRODUCT OR DAMAGES RESULTING FROM OR ATTRIBUTABLE TO DEFECTS IN THE PRODUCT.

No one other than TOYOTOMI has authority to extend or modify the terms of this Limited Warranty in any manner whatsoever.

Some states or provinces do not allow the exclusion or limitation of incidental or consequential damages or limitations on how long an implied warranty lasts, so these limitations or exclusions may not apply to you. This Limited Warranty gives you specific legal rights and you may also have other rights that vary from state to state, or province to province.

* In addition to the warranty period stated above, an extended two (2) year warranty (3 years from date of purchase) is on for the following parts. :

- A. Burner Pot
- B. Heat Chamber (Excluding Glass Cylinder)
- C. Heat Exchanger

NOTE : THE EXTENDED WARRANTY POLICY IS APPLICABLE ONLY FOR THE REPLACEMENT OF THE ORIGINAL FACTORY-INSTALLED PARTS THAT HAVE FAILED WITHIN THE TIME LIMITATIONS AS INDICATED. REPLACEMENT PARTS ARE WARRANTED FOR THE REMAINDER OF THE ORIGINAL PART WARRANTY PERIOD. LABOR IS NOT COVERED ON THE EXTENDED WARRANTY.

8368002060



TOYOTOMI U.S.A., INC.

604 Federal Road, Brookfield, CT 06804
www.toyotomiusa.com

Rev. 04/15

Part #20470695

Printed in Japan